

SPECIFICATIONS	
TURNTABLE DIAMETER:	157 $\frac{1}{2}$ " , [4000mm]
TURNTABLE HEIGHT:	3 $\frac{3}{16}$ "
TURNTABLE SPEED:	CW/CCW 0.1-1.25 RPM
LOAD CAPACITY:	6,000 LBS
MOTOR AND DRIVE:	NORD 0.75 HP 230V/3Φ/60Hz @ 2.16 FLA
CONCRETE FLATNESS DEVIATION	±.125"
POWER REQUIREMENTS	120V, 1φ, 60HZ, 6A

40SSV CONTROL BOX FEATURES

- EDISON PLUG & MOTOR CABLING
- CIRCUIT BREAKER
- VARIABLE FREQUENCY DRIVE
- WI-FI SWITCH WITH BUILT IN RF RECEIVER FOR REMOTE CONTROL

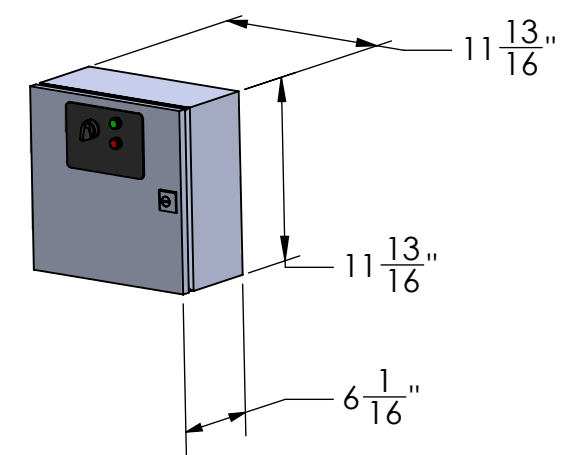

RAMP DIAMETER
 $\phi 178\frac{1}{2}$ "

DESIGN BY:	D.OLIVERIO	5/5/2020
DRAWN BY:	M.CASTRO	1/22/2021



UNLESS OTHERWISE NOTED
 DIMENSIONS ARE IN INCHES

TOLERANCES

.X = ± .125
 .XX = ± .0625
 .XXX = ± .010

FRACTIONAL = ± 1/16"

ANGLES = ± .5

TITLE: DX40SSV SURFACE MOUNTED TURNTABLE DIMENSIONS AND SPECS				
CAROUSEL USA 15206 Ceres Avenue Fontana, CA 92335 TEL: (626) 334-7190 FAX: (626) 236-4060 www.Carousel-USA.com	PROPRIETARY AND CONFIDENTIAL The information contained in this drawing is the sole property of Carousel USA. Any reproduction in part or as a whole without the written permission of Carousel USA is prohibited.	SIZE B	DWG. NO. GA-40SSV	REV -
SCALE: 1:22		DO NOT SCALE DRAWING	SHEET 1 OF 5	

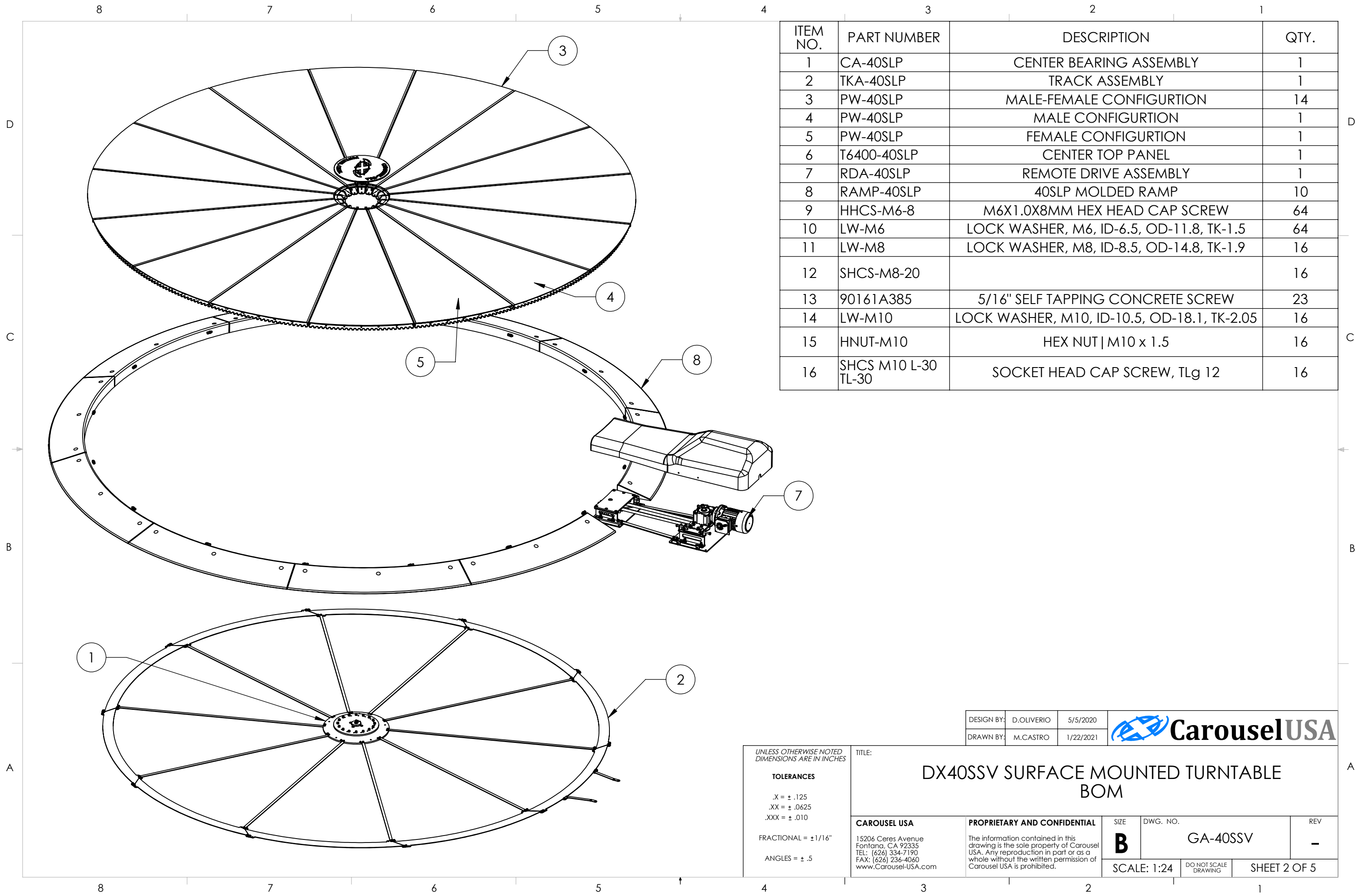

ITEM NO.	PART NUMBER	DESCRIPTION	QTY.
1	CA-40SLP	CENTER BEARING ASSEMBLY	1
2	TKA-40SLP	TRACK ASSEMBLY	1
3	PW-40SLP	MALE-FEMALE CONFIGURTION	14
4	PW-40SLP	MALE CONFIGURTION	1
5	PW-40SLP	FEMALE CONFIGURTION	1
6	T6400-40SLP	CENTER TOP PANEL	1
7	RDA-40SLP	REMOTE DRIVE ASSEMBLY	1
8	RAMP-40SLP	40SLP MOLDED RAMP	10
9	HHCS-M6-8	M6X1.0X8MM HEX HEAD CAP SCREW	64
10	LW-M6	LOCK WASHER, M6, ID-6.5, OD-11.8, TK-1.5	64
11	LW-M8	LOCK WASHER, M8, ID-8.5, OD-14.8, TK-1.9	16
12	SHCS-M8-20		16
13	90161A385	5/16" SELF TAPPING CONCRETE SCREW	23
14	LW-M10	LOCK WASHER, M10, ID-10.5, OD-18.1, TK-2.05	16
15	HNUT-M10	HEX NUT M10 x 1.5	16
16	SHCS M10 L-30 TL-30	SOCKET HEAD CAP SCREW, TLg 12	16

DESIGN BY: D.OLIVERIO 5/5/2020
 DRAWN BY: M.CASTRO 1/22/2021

UNLESS OTHERWISE NOTED
 DIMENSIONS ARE IN INCHES

TOLERANCES

.X = ± .125
 .XX = ± .0625
 .XXX = ± .010

FRACTIONAL = ± 1/16"

ANGLES = ± .5

TITLE: **DX40SSV SURFACE MOUNTED TURNTABLE BOM**

CAROUSEL USA 15206 Ceres Avenue Fontana, CA 92335 TEL: (626) 334-7190 FAX: (626) 236-4060 www.Carousel-USA.com	PROPRIETARY AND CONFIDENTIAL The information contained in this drawing is the sole property of Carousel USA. Any reproduction in part or as a whole without the written permission of Carousel USA is prohibited.	SIZE: B	DWG. NO.: GA-40SSV	REV: -
SCALE: 1:24		DO NOT SCALE DRAWING	SHEET 2 OF 5	

8 7 6 5 4 3 2 1

D
C
B
A

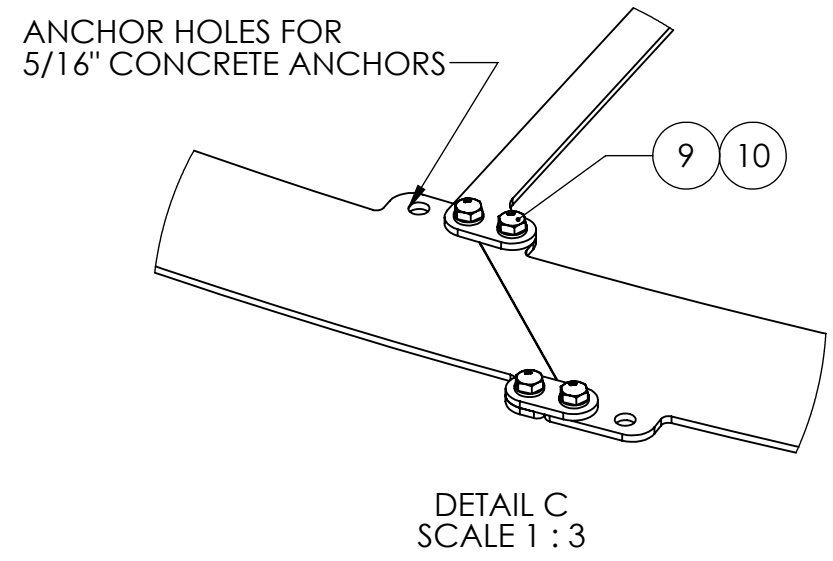
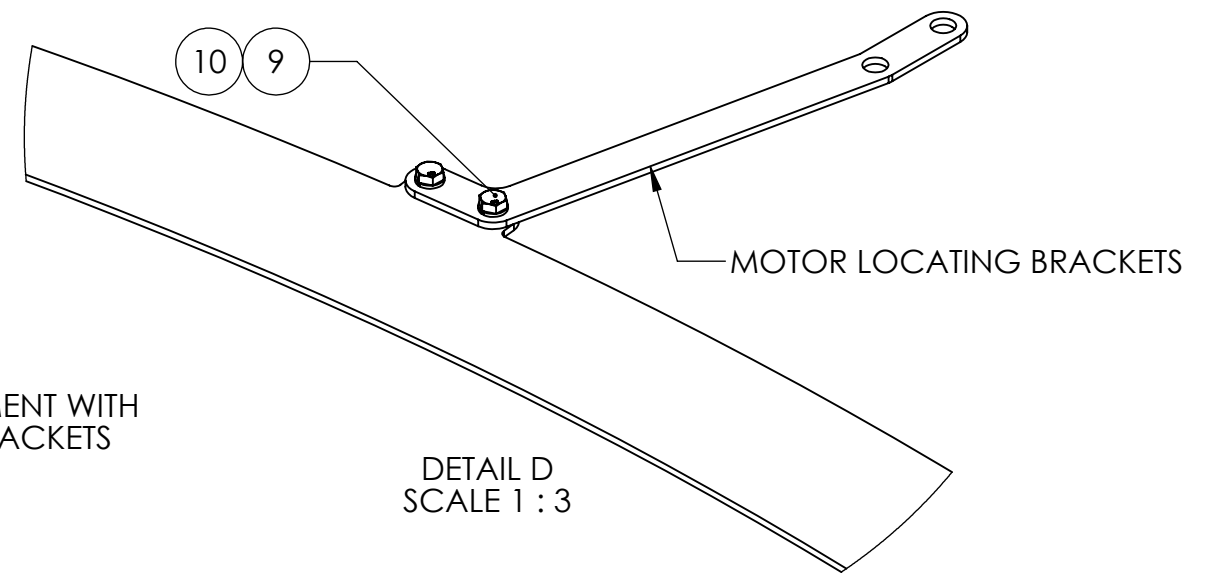
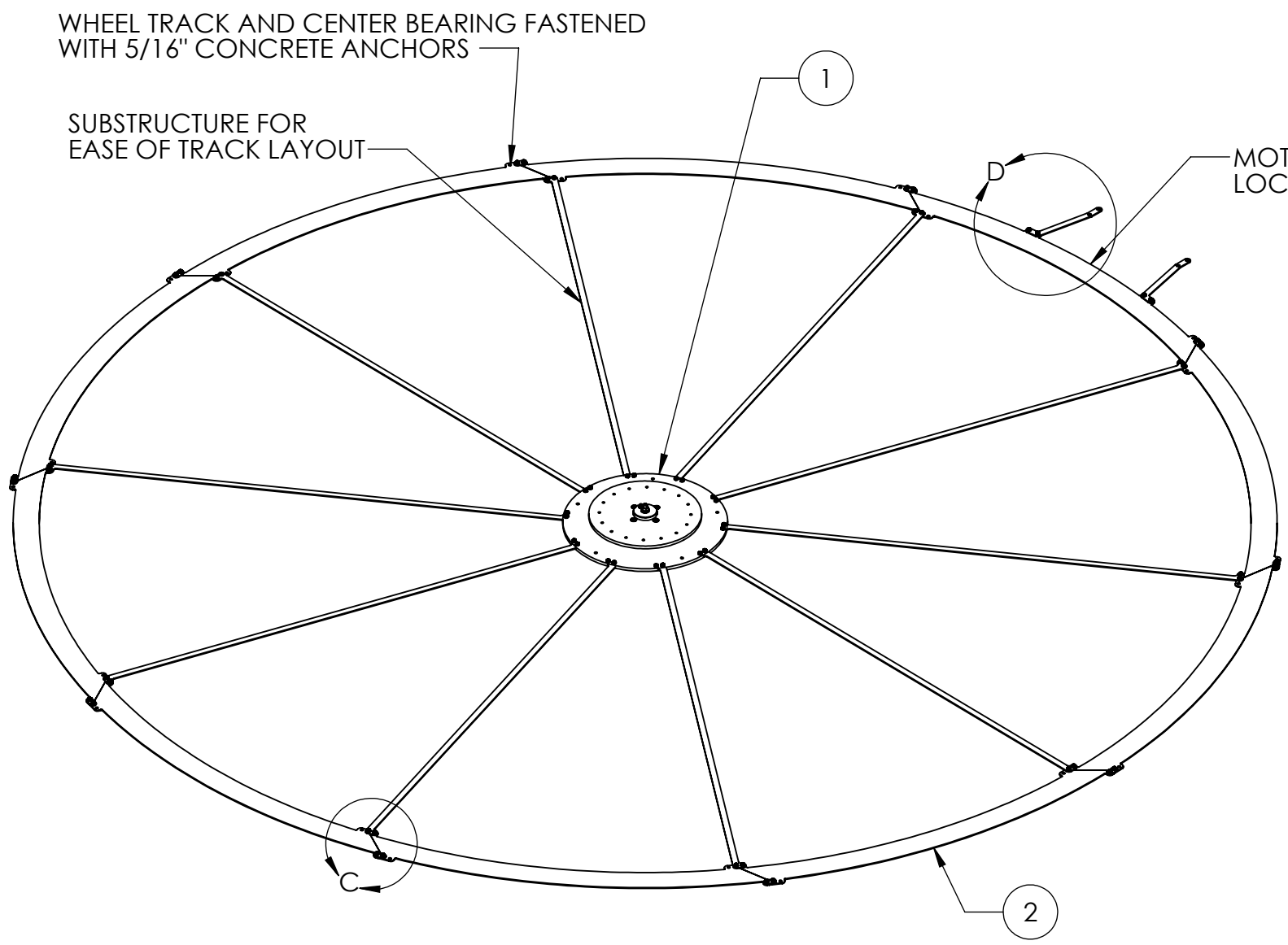

NOTE:
1. LEVEL, SMOOTH CONCRETE REQUIRED, NO MORE THAN 1/8" DEVIATION

DESIGN BY:	D. OLIVERIO	5/5/2020	
DRAWN BY:	M. CASTRO	1/22/2021	

UNLESS OTHERWISE NOTED DIMENSIONS ARE IN INCHES		TITLE: DX40SSV SURFACE MOUNTED TURNTABLE TRACK/CENTER BEARING LAYOUT				
TOLERANCES .X = ± .125 .XX = ± .0625 .XXX = ± .010 FRACTIONAL = ± 1/16" ANGLES = ± .5		CAROUSEL USA 15206 Ceres Avenue Fontana, CA 92335 TEL: (626) 334-7190 FAX: (626) 236-4060 www.Carousel-USA.com	PROPRIETARY AND CONFIDENTIAL The information contained in this drawing is the sole property of Carousel USA. Any reproduction in part or as a whole without the written permission of Carousel USA is prohibited.	SIZE B	DWG. NO. GA-40SSV	REV -
		SCALE: 1:18		DO NOT SCALE DRAWING	SHEET 3 OF 5	

8 7 6 5 4 3 2 1

8 7 6 5 4 3 2 1

D
C
B
A

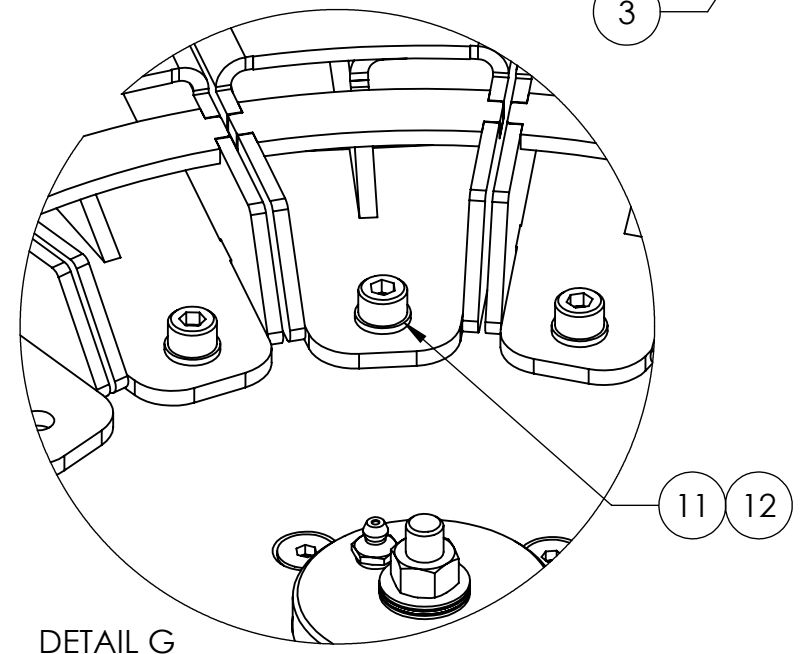
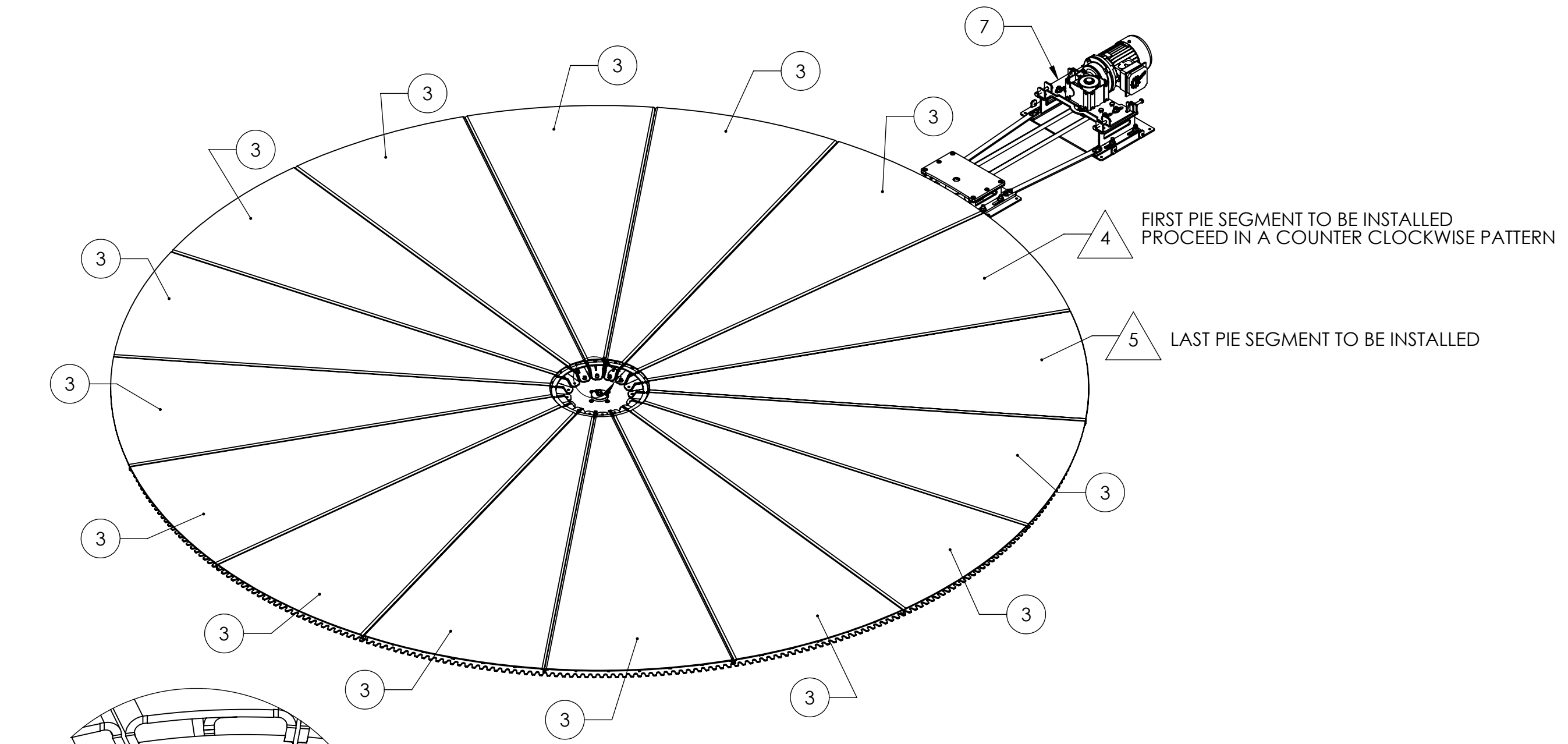

DETAIL G
SCALE 1 : 2

DESIGN BY:	D.OLIVERIO	5/5/2020
DRAWN BY:	M.CASTRO	1/22/2021



UNLESS OTHERWISE NOTED DIMENSIONS ARE IN INCHES		TITLE: DX40SSV SURFACE MOUNTED TURNTABLE PIE AND MOTOR LAYOUT				
TOLERANCES .X = ± .125 .XX = ± .0625 .XXX = ± .010 FRACTIONAL = ± 1/16" ANGLES = ± .5		CAROUSEL USA 15206 Ceres Avenue Fontana, CA 92335 TEL: (626) 334-7190 FAX: (626) 236-4060 www.Carousel-USA.com	PROPRIETARY AND CONFIDENTIAL The information contained in this drawing is the sole property of Carousel USA. Any reproduction in part or as a whole without the written permission of Carousel USA is prohibited.	SIZE B	DWG. NO. GA-40SSV	REV -
		SCALE: 1:18	DO NOT SCALE DRAWING	SHEET 4 OF 5		

8 7 6 5 4 3 2 1

8 7 6 5 4 3 2 1

D
C
B
A

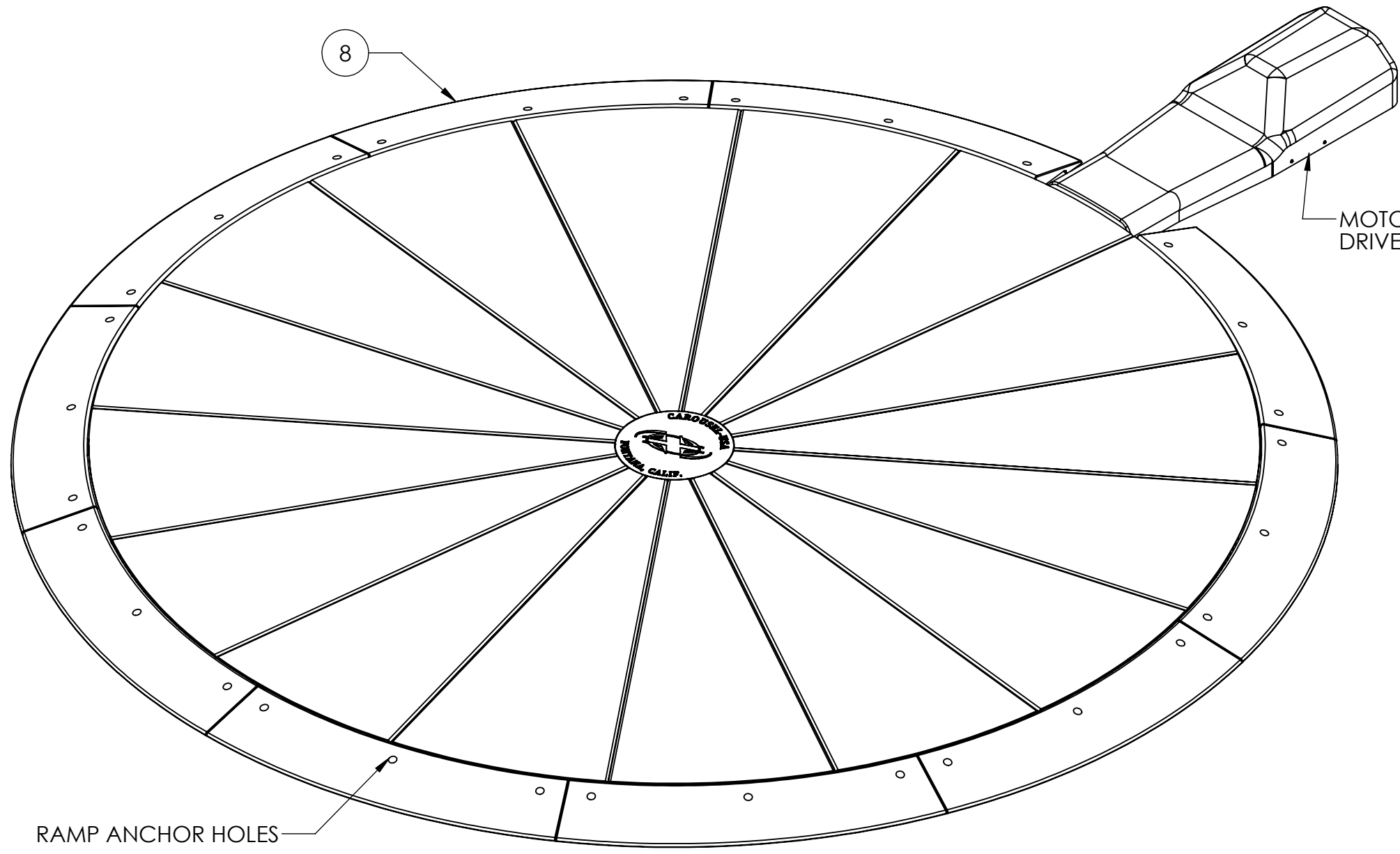

DESIGN BY:	D.OLIVERIO	5/5/2020
DRAWN BY:	M.CASTRO	1/22/2021



UNLESS OTHERWISE NOTED
DIMENSIONS ARE IN INCHES

TOLERANCES

.X = ± .125
.XX = ± .0625
.XXX = ± .010

FRACTIONAL = ± 1/16"

ANGLES = ± .5

TITLE: **DX40SSV SURFACE MOUNTED TURNTABLE RAMP LAYOUT**

CAROUSEL USA 15206 Ceres Avenue Fontana, CA 92335 TEL: (626) 334-7190 FAX: (626) 236-4060 www.Carousel-USA.com	PROPRIETARY AND CONFIDENTIAL The information contained in this drawing is the sole property of Carousel USA. Any reproduction in part or as a whole without the written permission of Carousel USA is prohibited.	SIZE B	DWG. NO. GA-40SSV	REV -
SCALE: 1:18		DO NOT SCALE DRAWING	SHEET 5 OF 5	

8 7 6 5 4 3 2 1