

SPECIFICATIONS

LIFTING CAPACITY:	12,000 LB	PER LIFT
STATIC CAPACITY	6,000 LB	PER PLATFORM
TRAVEL:	90 IN	
LIFT RAISED TIME:	60 S	BASED ON AVAILABLE POWER: 240/60/3
LIFT LOWERING TIME:	60 S	APPROX. DEPENDENT ON LOAD

DIMENSIONS

A. PIT LENGTH	217"
B. PIT WIDTH	218"
C. OVERALL DEPTH	120"
D. FLOOR TO FLOOR	N/A
E. PLATFORM LENGTH	216"
F. PLATFORM WIDTH	108"
G. CLEAR LENGTH	192 1/2"
H. CLEAR WIDTH	97"
I. CLEAR HEIGHT	83 13/16"
J. LANDING HEIGHT	30"
K. GAP, LIFT TO CONCRETE	1/2"
L. GAP, LIFT TO LIFT	1"
M. CYLINDER CLEARANCE	177 1/8"
N. CYLINDER CLEARANCE	96 1/2"
O. CORNER ANGLE CLEARANCE	85"

NOTES:

- LIMIT SWITCH, FULLY UP INCLUDED.
- LIMIT SWITCH, FULLY DOWN INCLUDED.
- GARAGE DOOR SAFETY LOCK OUT SYSTEM INCLUDED.
- AUTO RE-PRESSURIZATION CIRCUIT.
- POWDER COAT FINISH. COLOR TBD.

DESIGN	M.CASTRO	9/3/2016
DRAWN	L.LUCAS	6/27/2017



TITLE:			
4PL90 - MELLER RESIDENCE LIFT GENERAL ARRANGEMENT			
CAROUSEL USA 6370 N. Irwindale Ave. Irwindale CA, 91702 TEL: (626) 334-7190 FAX: (626) 236-4060 www.Carousel-USA.com	PROPRIETARY AND CONFIDENTIAL The information contained in this drawing is the sole property of Carousel USA. Any reproduction in part or as a whole without the written permission of Carousel USA is prohibited.	SIZE B	DWG. NO. 4PL90 ---1
		SCALE: 1:40	REV 5
		DO NOT SCALE DRAWING	SHEET 1 OF 5

NOT FOR CONSTRUCTION

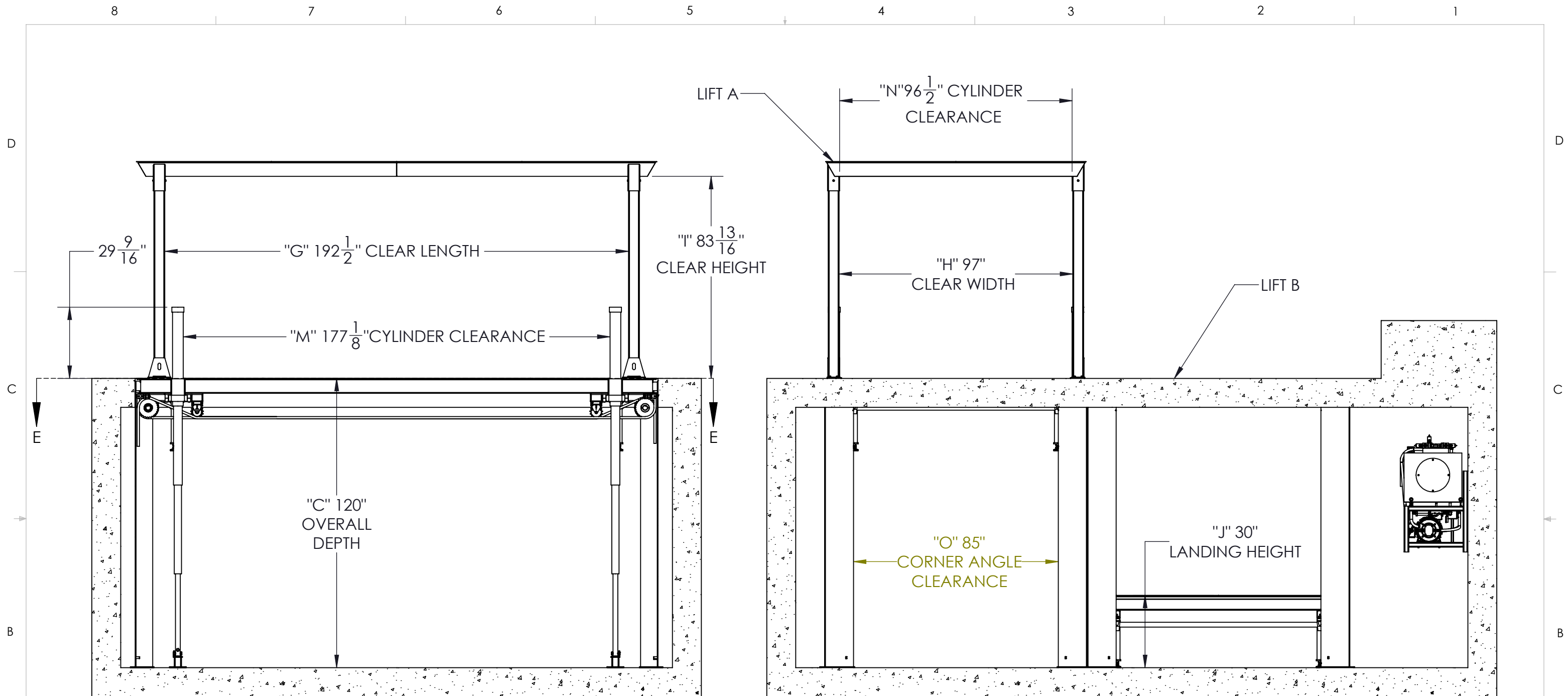

ELEVATION VIEW
LIFT A RAISED POSITION
(LIFT B NOT SHOWN FOR CLARITY)

ELEVATION VIEW
LIFT A IN RAISED POSITION
LIFT B IN LOWERED POSITION

NOT FOR CONSTRUCTION

DESIGN	M.CASTRO	9/3/2016	
DRAWN	L.LUCAS	6/27/2017	

TITLE: 4PL90 - MELLER RESIDENCE LIFT GENERAL ARRANGEMENT- ELAVATION			
CAROUSEL USA 6370 N. Irwindale Ave. Irwindale CA, 91702 TEL: (626) 334-7190 FAX: (626) 236-4060 www.Carousel-USA.com	PROPRIETARY AND CONFIDENTIAL The information contained in this drawing is the sole property of Carousel USA. Any reproduction in part or as a whole without the written permission of Carousel USA is prohibited.	SIZE B	DWG. NO. 4PL90 ---2
SCALE: 1:40		DO NOT SCALE DRAWING	REV 5
			SHEET 2 OF 5

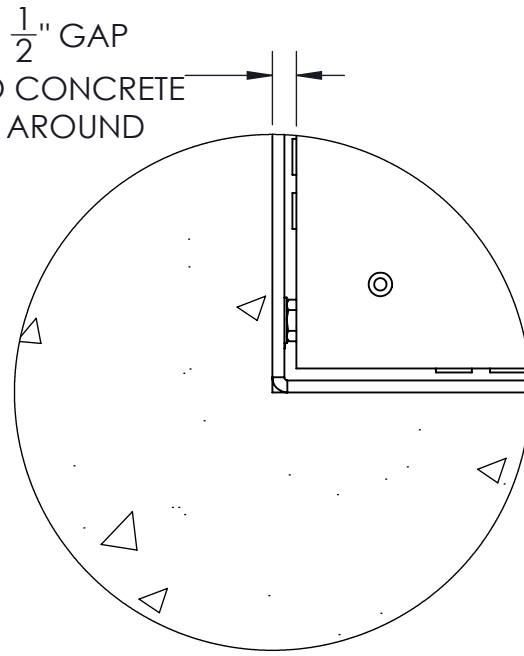
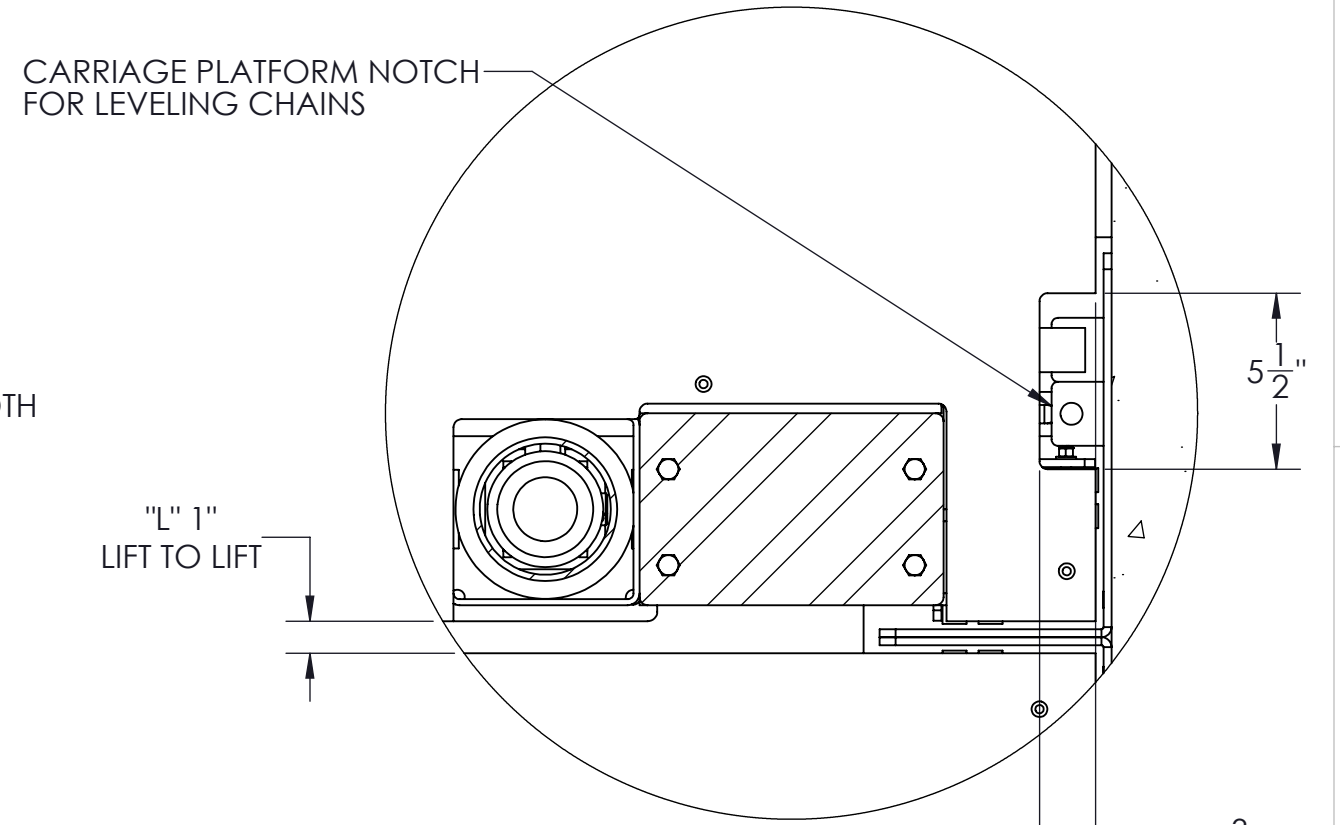
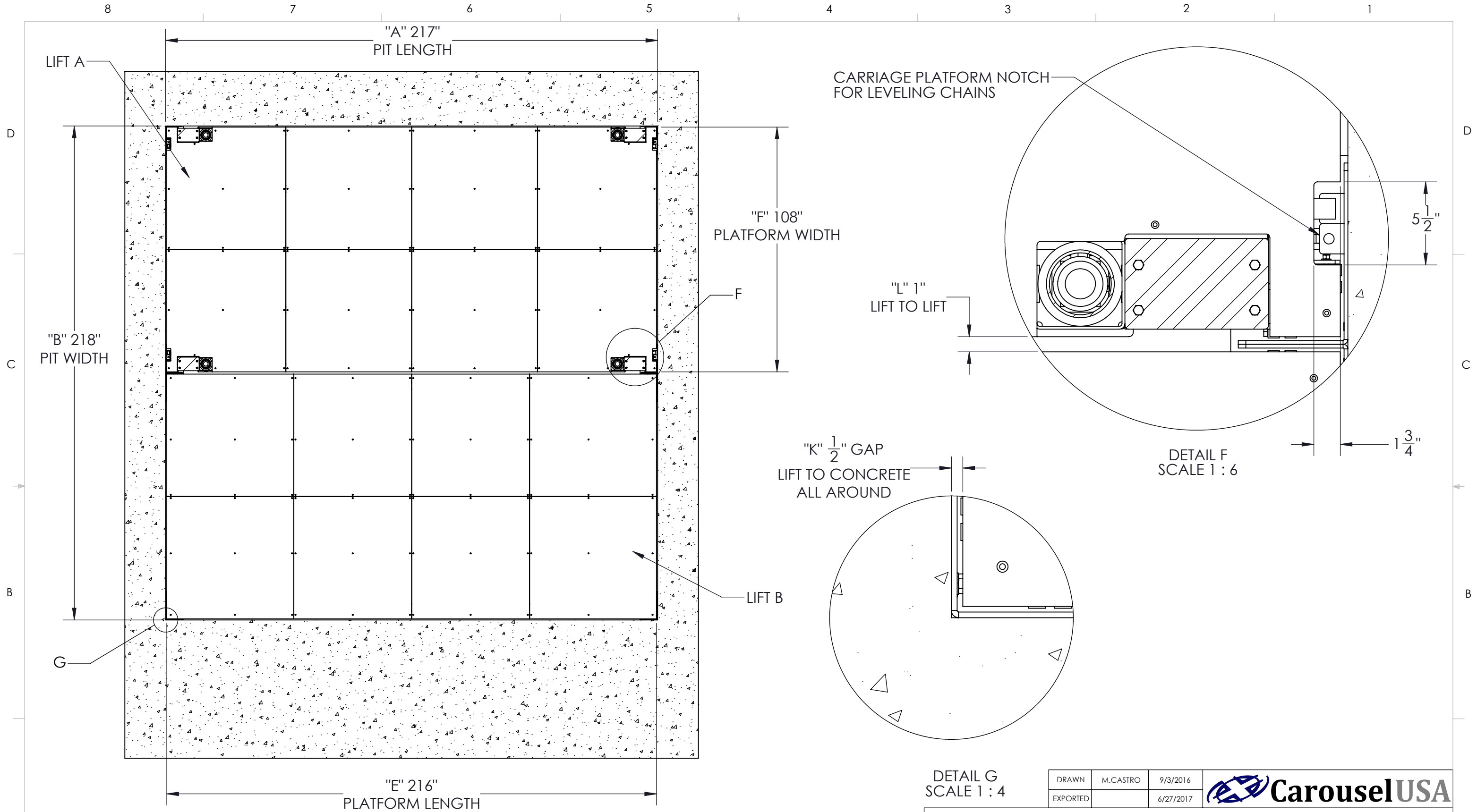

DRAWN	M.CASTRO	9/3/2016	
EXPORTED		6/27/2017	

TITLE:
**4PL90 MELLER RESIDENCE LIFT
 GENERAL ARRANGEMENT-PLAN VIEW**

CAROUSEL USA 6370 N. Irwindale Ave. Irwindale CA, 91702 TEL: (626) 334-7190 FAX: (626) 236-4060 www.Carousel-USA.com	PROPRIETARY AND CONFIDENTIAL The information contained in this drawing is the sole property of Carousel USA. Any reproduction in part or as a whole without the written permission of Carousel USA is prohibited.	SIZE B	DWG. NO. 4PL90 ---3	REV 5
		SCALE: 1:30	DO NOT SCALE DRAWING	SHEET 3 OF 5

NOT FOR CONSTRUCTION

8 7 6 5 4 3 2 1

D
C
B
A

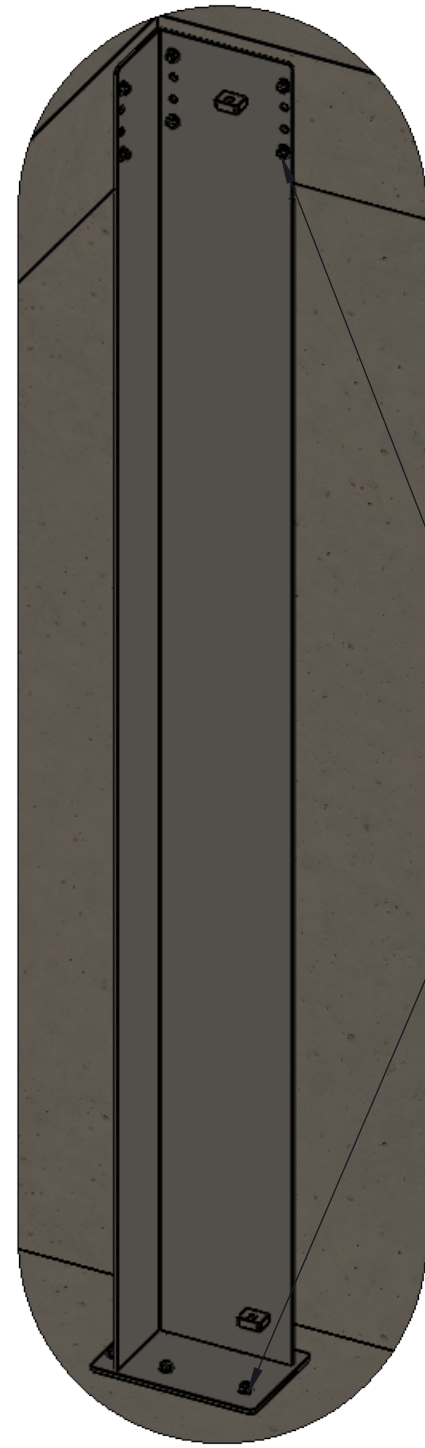

DETAIL J
SCALE 1 : 15

Ø .6 THRU
FOR 1/2" CONCRETE
ANCHORS
INTO GROUND

Ø .6 THRU
FOR 1/2" CONCRETE
ANCHORS
INTO WALL

1/2" CONCRETE
ANCHOR

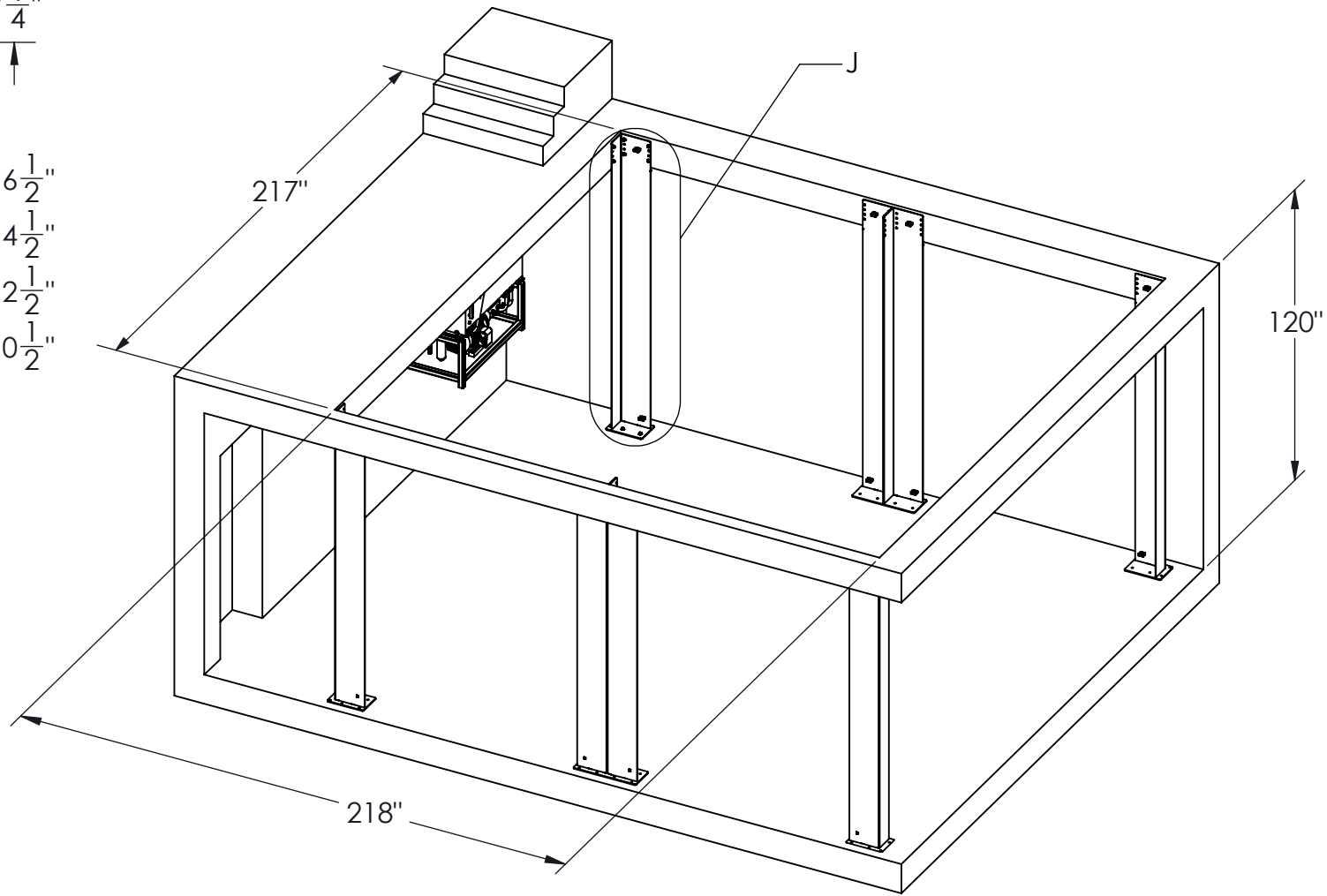
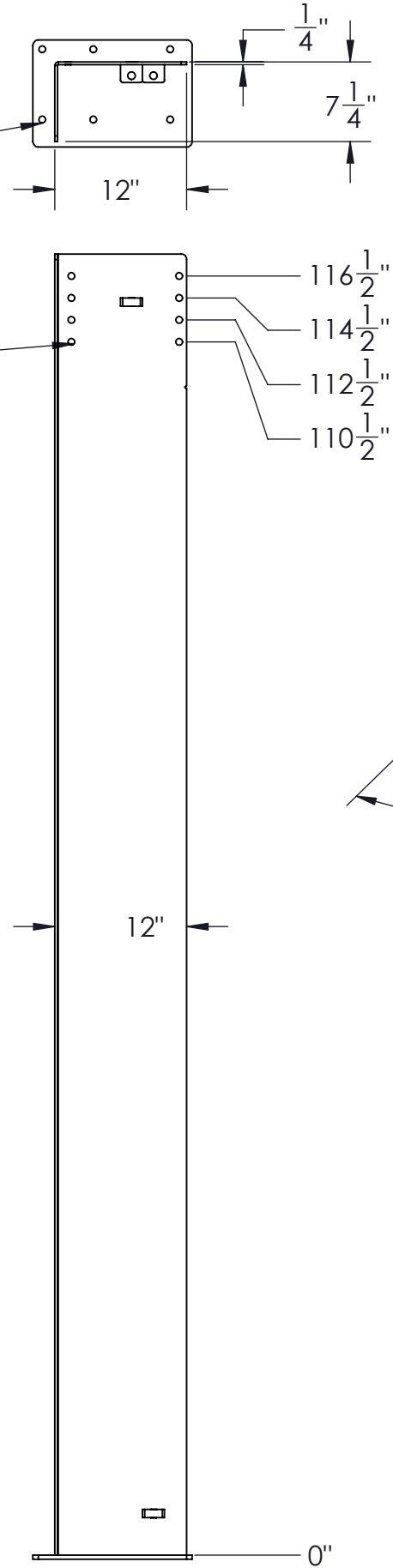

D
C
B
A

NOTE:

STEEL CORNER ANGLES INSTALLED BY CAROUSEL USA TECHNICIANS. CONCRETE MUST BE ADEQUATELY PREPARED FOR SUCCESSFUL INSTALLATION. INCORRECT SIZE, SLOPE, MISALIGNMENT, OR POOR QUALITY CONCRETE WILL NEGATIVELY AFFECT LIFT INSTALLATION.

NOT FOR CONSTRUCTION

DRAWN	M.CASTRO	9/3/2016
EXPORTED		6/27/2017



TITLE:								
4PL90 MELLER RESIDENCE LIFT GENERAL ARRANGEMENT-CORNER								
CAROUSEL USA 6370 N. Irwindale Ave. Irwindale CA, 91702 TEL: (626) 334-7190 FAX: (626) 236-4060 www.Carousel-USA.com	PROPRIETARY AND CONFIDENTIAL The information contained in this drawing is the sole property of Carousel USA. Any reproduction in part or as a whole without the written permission of Carousel USA is prohibited.	<table border="1"> <tr> <td>SIZE</td> <td>DWG. NO.</td> <td>REV</td> </tr> <tr> <td>B</td> <td>4PL90 ---4</td> <td>5</td> </tr> </table>	SIZE	DWG. NO.	REV	B	4PL90 ---4	5
SIZE	DWG. NO.	REV						
B	4PL90 ---4	5						
SCALE: 1:15	DO NOT SCALE DRAWING	SHEET 4 OF 5						

8 7 6 5 4 3 2 1

8 7 6 5 4 3 2 1

D
C
B
A

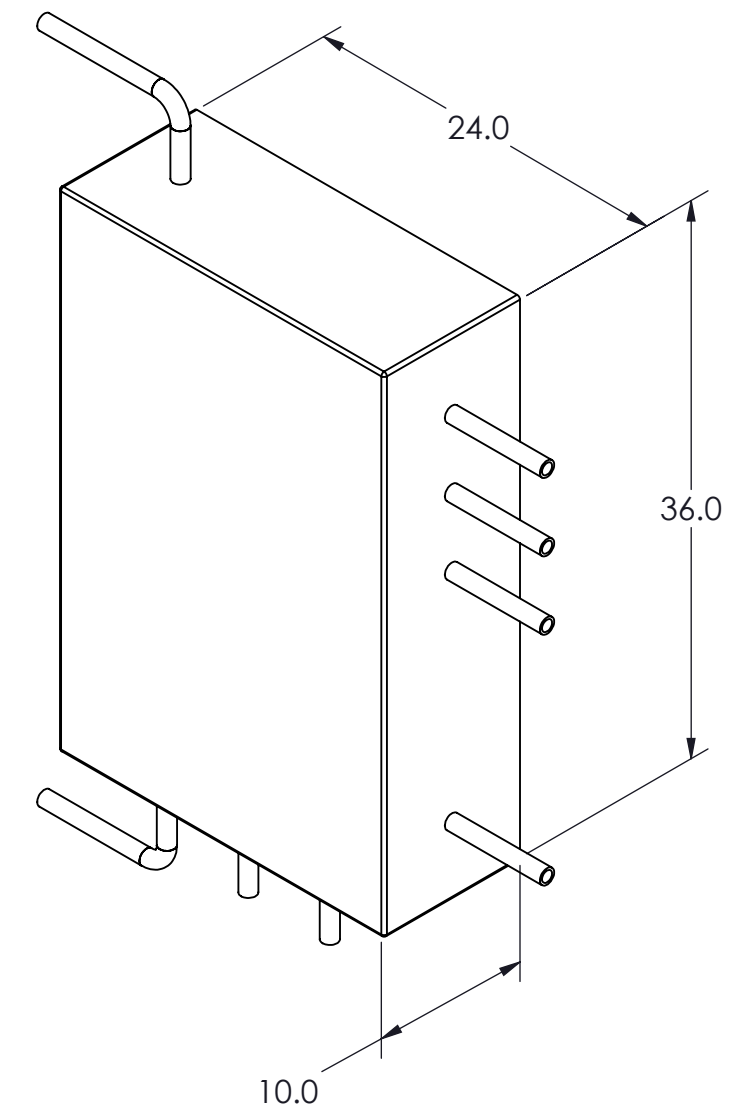
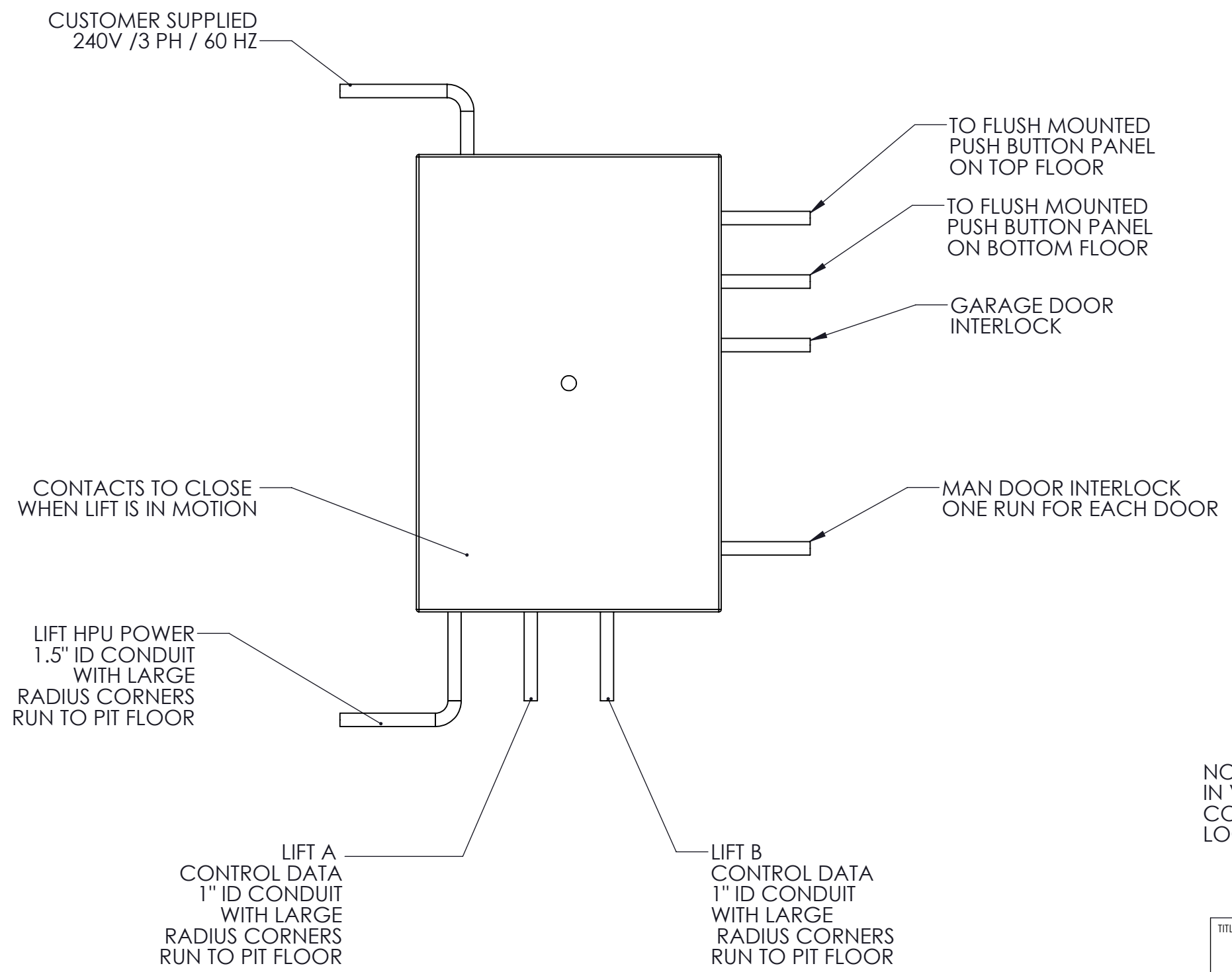

NOTE: CONTROL BOX TO BE LOCATED
IN VENTILATED LOCATION WITH APPROPRIATE ACCESS.
CONTROLS WILL BE LOCATED ON FLUSH MOUNTED PANELS
LOCATED ON UPPER AND (OPTIONAL) LOWER FLOOR.

DRAWN	M.CASTRO	10/22/2014
EXPORTED		10/4/2018



TITLE:
**4PL90 MELLER RESIDENCE LIFT
ELECTRICAL-CONTROL BOX**

CAROUSEL USA 6370 N. Irwindale Ave. Irwindale CA, 91702 TEL: (626) 334-7190 FAX: (626) 236-4060 www.Carousel-USA.com	PROPRIETARY AND CONFIDENTIAL The information contained in this drawing is the sole property of Carousel USA. Any reproduction in part or as a whole without the written permission of Carousel USA is prohibited.	SIZE	DWG. NO.	REV
		B	--1	4
SCALE: 1:10		DO NOT SCALE DRAWING	SHEET 1 OF 2	

NOT FOR CONSTRUCTION

8 7 6 5 4 3 2 1

8 7 6 5 4 3 2 1

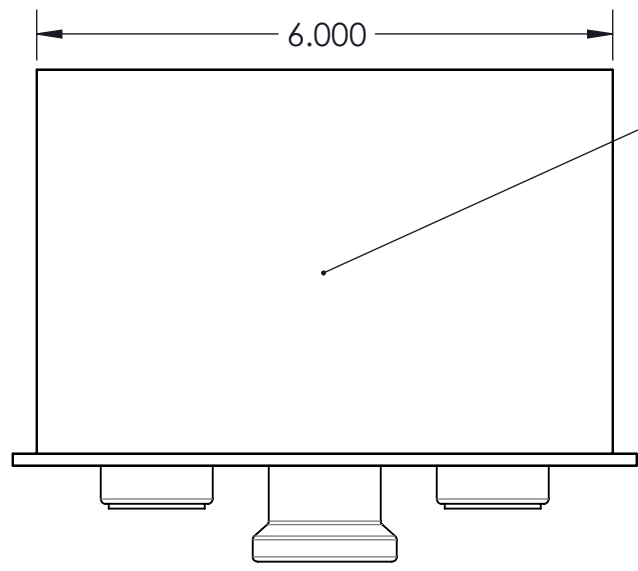

CAROUSEL USA TO PROVIDE BOX AND PANEL INSTALLED FLUSH IN WALL BY OTHERS

NOTE:
ONE PANEL INCLUDED FOR INSTALLATION ON UPPER FLOOR. SECOND PANEL ON LOWER FLOOR OPTIONAL.

D

D

C

C

B

B

A

A

INSERT KEY
TWIST LEFT OR RIGHT TO
SELECT A OR B THREE
POSITION SELECTOR

GREEN LED INDICATES
STATUS OF LIFT ILLUMINATED
WHEN LIFT IS FULLY RAISED
OR LOWERED OFF WHEN
NEITHER LIFT SELECTED

STAINLESS STEEL FINISH
WITH BLACK LASER THERMARK MARKING
ALL CAPITAL LETTER HELVETICA FONT
22MM ALLEN BRADLEY SWITCH SERIES
(CHROME BEZEL WHERE APPLICABLE)

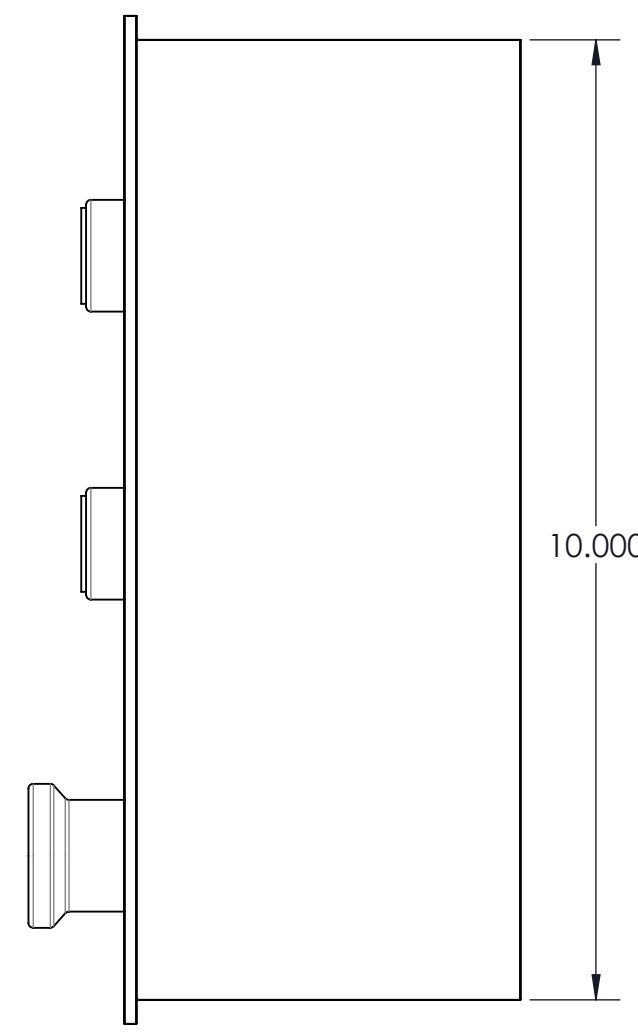
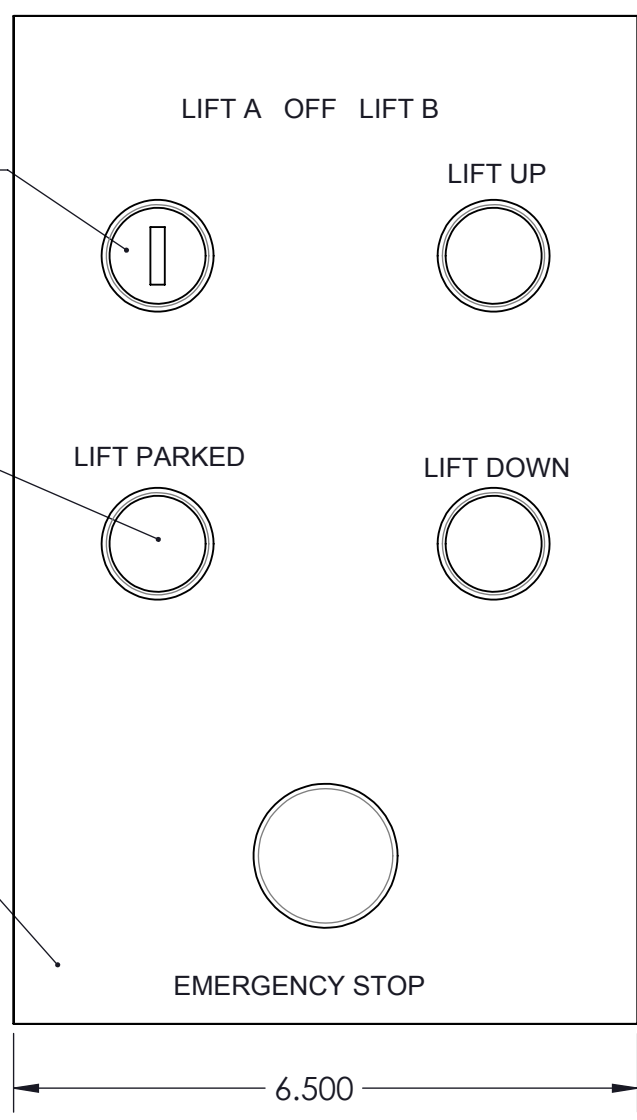

DRAWN	M.CASTRO	10/22/2014
EXPORTED		10/4/2018



TITLE:
**4PL90 MELLER RESIDENCE LIFT
ELECTRICAL- CONTROL PANEL**

NOT FOR CONSTRUCTION

CAROUSEL USA 6370 N. Irwindale Ave. Irwindale CA, 91702 TEL: (626) 334-7190 FAX: (626) 236-4060 www.Carousel-USA.com	PROPRIETARY AND CONFIDENTIAL The information contained in this drawing is the sole property of Carousel USA. Any reproduction in part or as a whole without the written permission of Carousel USA is prohibited.	SIZE B	DWG. NO. --2	REV 4
		SCALE: 1:2	DO NOT SCALE DRAWING	SHEET 2 OF 2

8 7 6 5 4 3 2 1

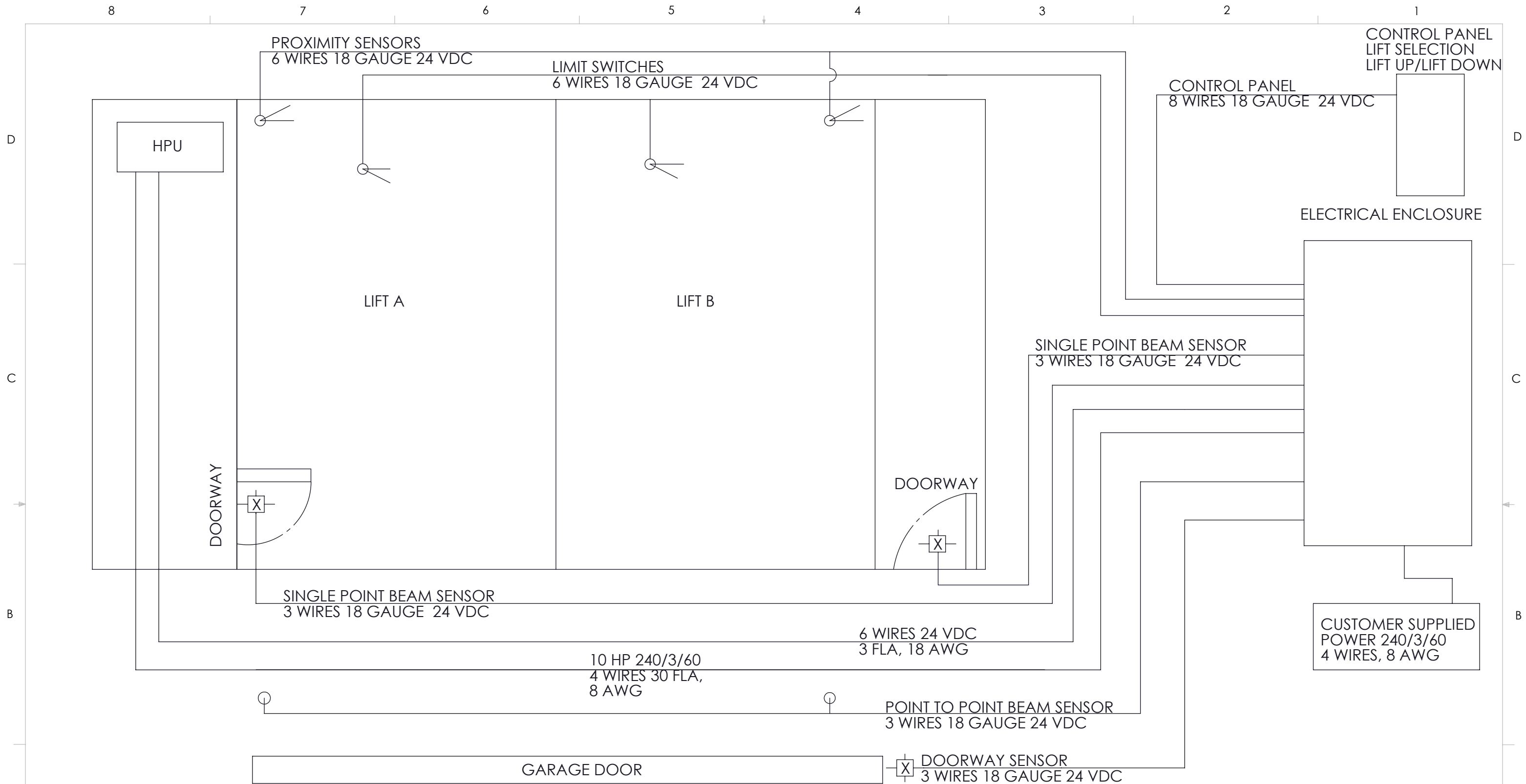

NOTE: LABEL WIRES FOR IDENTIFICATION

DRAWN	M.CASTRO	8/28/2017	
EXPORTED		10/4/2018	

TITLE: **MELLER INTERCONNECT**

NOT FOR CONSTRUCTION

CAROUSEL USA 6370 N. Irwindale Ave. Irwindale CA, 91702 TEL: (626) 334-7190 FAX: (626) 236-4060 www.Carousel-USA.com	PROPRIETARY AND CONFIDENTIAL The information contained in this drawing is the sole property of Carousel USA. Any reproduction in part or as a whole without the written permission of Carousel USA is prohibited.	SIZE B	DWG. NO. --1	REV 2
SCALE: 1:1		DO NOT SCALE DRAWING	SHEET 1 OF 1	