

SCB Controller Outline

Contents

1. Introduction	2
a. Content of Carousel USA Agreement.....	2
b. System Features.....	2
c. Components.....	2
2. Control Panel.....	2
a. Enclosure Specifications.....	2
b. Connections	2
c. Features and Functions.....	3
d. Front Panel Layout	3
e. Drawing.....	3
f. Electrical Schematic	3
3. Remote Control (Transmitter)	4
a. Specifications	4
b. Features and Functions.....	4
c. Remote Control Button Layout.....	4
4. Standard Operating Procedure	5

Revised 4/8/2026

Carousel USA

15206 Ceres Ave, Fontana, CA 92335

www.carousel-usa.com

Proprietary Information

Carousel USA has proprietary rights on the information in this document. It is forbidden to copy, duplicate or disclose the information herein, in whole or in part, or make use of the information, unless permission has been previously obtained, in writing, from Carousel USA.

1. Introduction

This document is intended to further detail the standard turntable controller equipment described in the contractual agreement. It will cover functionality and provides step-by-step standard operating procedures.

a. Content of Carousel USA Agreement

CUSA Standard Controls, with one (1) or two (2) TeleRadio remote transmitters.

b. System Features

This system has all features listed in a separate document named *Standard Turntable Controller User Manual*.

c. Components

Enclosure:	JB161406HC	Rittal H16" x W14"x D6" Steel Enclosure
VFD:	22F-A8P0N103	Allen Bradley PowerFlex 4M 240V 1.5hp
Disconnect:	OT16F3	ABB Disconnect Switch
	OHYS2AJ	ABB Disconnect Switch Handle
	OXS6X130	ABB 130mm Disconnect Shaft
Circuit Breaker:	L9-15/2/D	Sprecher+Schuh Circuit breaker, AC, 15A 2-pole
Operators:	800FD-SB32X20	Allen-Bradley 3-Pos. Spring-Return Selector Switch
	LB1P-1TO4G	IDEC Green LED Indicator
	LB1P-1TO4R	IDEC Red LED Indicator
Receiver/Transmitter:	T60RX-05ASL	Teleradio Panther Wireless Receiver, 433Mhz
	T60-T8-52	Teleradio Panther Wireless Transmitter, 433Mhz

2. Control Panel

a. Enclosure Specifications

- Carbon steel housing and door, RAL 7035 light gray, dip-coat primed, powder-coated
- One-piece welded cold-rolled steel body
- Left-hand hinged door
- Single quarter-turn latch with screwdriver insert
- Foamed-in-place gasket
- 4 wall mounting holes
- UL Type 1 (other ratings available on request)
- Recommended enclosure location: within 50ft of motor. For best wireless remote performance, locate panel in direct line-of-sight of turntable.

b. Connections

- Incoming Power
 - Voltage: 208-240V/1Φ/60Hz

- Required Amperage: 15A
- Conduit to motor pit
 - Motor Horsepower:
 - 1HP, 240V, 3Φ, 2.89A
 - 1.5HP, 240V, 3Φ, 4.34A
 - 2HP, 240V, 3Φ, 5.78A

c. Features and Functions

The following operators will be available on the front of the control panel:

- **CW/CCW Spring-return Selector Switch**
Jogs turntable clockwise or counterclockwise. Table will stop when the switch is released.
- **POWER Green Indicator Light**
Illuminates when control panel is powered.
- **FAULT Red Indicator Light**
Illuminates when there is a fault in the system.
- **MAIN POWER Disconnect Switch**
Removes all power to the control panel.

d. Front Panel Layout



e. Drawing

See Attachment.

f. Electrical Schematic

See Attachment.

3. Remote Controller (Transmitter)

a. Specifications

- Frequency: 433MHz, 1 channel
- Output: 1 mW
- Buttons: 3x1 step
- Weight: 80g / 2.8 oz
- Dimensions: 83 x 52 x 17mm / 3.3 x 2 x 0.7 in
- Protection: IP67
- Batteries: 2 x 1.5V LR03 / AAA

b. Features and Functions

The following functions will be available on the remote control:

- **CCW**
Rotates turntable counterclockwise. The table will continue rotating until the CCW button is pressed again or the STOP button is pressed.
- **STOP/Clear**
Stops turntable. Clears all latched relays.
- **CW**
Rotates turntable clockwise. The table will continue rotating until the CW button is pressed again or the STOP button is pressed.

c. Remote Control Button Layout



4. Standard Operating Procedure

1. User will pull the vehicle onto the turntable.
2. User will exit the vehicle and use the front panel CCW/CW switch or the CCW/CW buttons on the remote control (transmitter) to turn the table in the desired direction.
3. Once the vehicle is in position, the user will release the CCW/CW switch or press the Stop button on the remote control, get back into the vehicle and either reverse or pull forward into the parking space.
4. **In the event of simultaneous directional inputs, the turntable will cease all movement to prevent signal conflict. To resume operation, press the Stop/Clear button to reset the system and clear all latched signals.**



CarouselUSA

Standard Turntable Controller **User Manual**



Revised 3/20/2022

Carousel USA

15206 Ceres Ave, Fontana, CA 92335

www.carousel-usa.com

Proprietary Information

Carousel USA has proprietary rights on the information in this document. It is forbidden to copy, duplicate or disclose the information herein, in whole or in part, or make use of the information, unless permission has been previously obtained, in writing, from Carousel USA.

CONTENTS

1. INTRODUCTION	4
A. SCOPE	4
B. FEATURES	4
2. BEING PREPARED ON THE DAY OF INSTALLATION	4
A. REQUIRED: HAVE AN ELECTRICIAN ON SITE DURING THE DAY OF INSTALLATION	4
B. GENERAL	5
3. OPERATION/SAFETY INSTRUCTIONS.....	5
4. SCB EXTERNAL LAYOUT	6
A. BASIC OPERATION	6
i. <i>Rotating Turntable</i>	6
ii. <i>Adjusting Turntable Speed</i>	6
B. FRONT PANEL INTERFACE	7
iii. <i>Lockable Disconnect</i>	7
iv. <i>Power Indicator</i>	7
v. <i>Fault Indicator</i>	7
vi. <i>CW/CCW Switch</i>	7
5. SCB INTERNAL LAYOUT.....	8
A. OPENING THE ENCLOSURE	8
6. REMOTE CONTROLLER.....	10
i. <i>CCW</i>	10
ii. <i>STOP</i>	10
iii. <i>CW</i>	10
7. TROUBLESHOOTING	11
A. THE ENCLOSURE DOOR DOES NOT CLOSE.....	11
B. THE "FAULT" LIGHT IS ILLUMINATED.....	11
C. THE REMOTE DOES NOT WORK	11
D. CLEARING FAULT CODES	11

1. Introduction

A. Scope

This manual provides a technical description and instructions for the installation, operation, and maintenance of the *Carousel USA Standard Controller SCB*.

B. Features

The *Carousel USA Residential Turntable* is designed with special features to fulfill system operation requirements as follows:

- Use of industrial grade UL listed components for longevity and safety
- High precision variable frequency drive to provide power to the motor

2. Being prepared on the day of installation

As an OEM, Carousel USA is responsible for the installation of our equipment only and cannot perform electrical work during our installation process.

SCB Installations require ONE conduit running from the control enclosure into the turntable pit.

1. One conduit will be used to carry motor power.

A. Required: Have an electrician on site during the day of installation

An electrician is required during the day of installation.

They are responsible for the following tasks:

1. Mounting the SCB enclosure to the wall.
2. Provide incoming power into control box, including penetration of enclosure.
Many installations are unique, but typically this incoming power requirement is Single phase 220V + GROUND with a 15A supply.
3. Size and supply motor power wire. Typical installation uses no more than 2hp motor. The motor power 3 Φ 220V is supplied from the VFD.
4. Fish the power wire from the enclosure to the turntable motor.
5. Land the power wires onto the terminal blocks or VFD.
6. Land the power wires onto the motor ensuring that the motor is wired for the appropriate voltage operation.
7. The SCB enclosure uses spring clamp terminal blocks. These require the use of a small flathead screwdriver to land the motor power wires. See the illustration below.

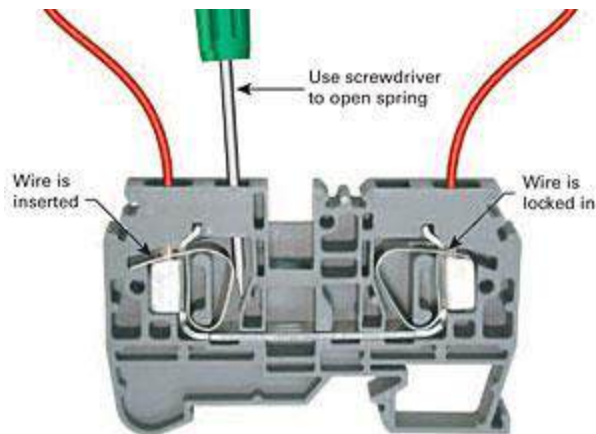

B. General

The controller is shipped in a case. Please do not unpack crates prior to installers' arrival. Make note of any damage that may have occurred during transit, and contact Carousel USA immediately if the damage looks significant enough to have affected the contents of the crate. The crates are marked with the correct individual weights, and one the cases *will require the use of a forklift to unload and move*. Please place the crates as close to the assembly site as possible.

3. Operation/Safety Instructions

CAUTION: Prior to any Operation of the Turntable, make sure that no person or equipment is inside the Turntable rotation area.

The residential turntable is designed for ease of use. Only a few cautions exist regarding operating the turntable.

1. Fully move the vehicle up onto the turntable platform, ensuring that all supports are completely on the turntable surface.
2. Place any vehicles in "Park", with parking brake applied.
3. Ensure that all people and pets are clear of interference with the vehicle and turntable surfaces.

Never allow riders!

4. SCB External Layout

The electronic equipment that drives the standard turn table system is mounted in a light gray powder coated steel enclosure.



A. Basic Operation

i. Rotating Turntable

Use the **CCW/CW** switch on the control panel, or the CCW/CW buttons on the remote controller to move the turntable as desired.

ii. Adjusting Turntable Speed

Turntable rotation speed can be adjusted via the potentiometer knob on the integral keypad of the AC motor drive, or VFD, located inside the control panel.

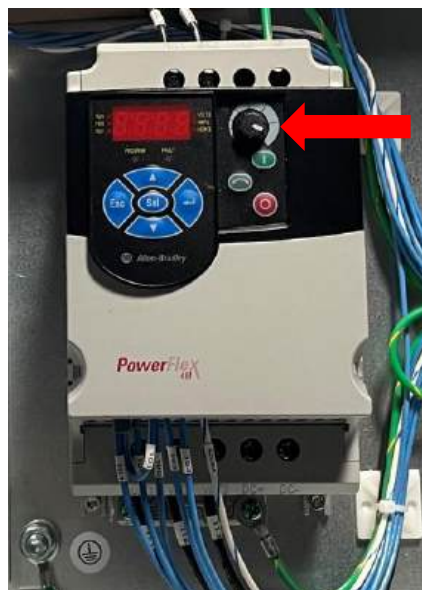

B. Front Panel Interface

iii. Lockable Disconnect

The SCB enclosure features a disconnect switch with multiple features.

- When it is set to the ON position, the panel is powered up and the enclosure cannot be opened.
- Or if set to the off position, the switch features a tab that can be pulled out which prevents the enclosure from opening. A padlock can be inserted through the tab to prevent users from activating the switch as well. If the tab is pushed back in the enclosure can be opened freely.
- **CAUTION, the following to be performed by authorized personnel only:** To circumvent this mechanical interlock and power up the system with the door open (Often necessary when troubleshooting), turn the system off, open the enclosure then use fingers or a tool to carefully switch the oval shaped disconnect on.

iv. Power Indicator

Illuminates when control panel is powered.

v. Fault Indicator

Illuminates when there is a fault in the system.

The red light illuminates to indicate that the VFD has experienced a fault. This may range from insignificant to a severe problem. Contact Carousel USA if a fault is persistent and prevents proper use of the equipment. Resetting a fault is covered in the troubleshooting section.

vi. CW/CCW Switch

The jog is a momentary spring-to-center 3-position selector switch. When in the center position, the switch is off. If rotated to the CW or CCW position, the table will accelerate to a preset jog speed then decelerate to a stop when the switch is released.

5. SCB Internal Layout

A. Opening the enclosure



Turn Off Main Power

WARNING

OPENING THE CONTROL BOX EXPOSES LIVE WIRING. ANY WORK PERFORMED INSIDE THE CONTROL BOX IS DONE AT THE USER'S OWN RISK. TO PREVENT ELECTRICAL SHOCK USE CAUTION WHENEVER WORKING NEAR EXPOSED WIRING OR CONNECTIONS.



Open control panel using coin, key, or screwdriver.



Manually turn power supply on inside control box.

6. Remote Controller

The following functions will be available on the remote controller:



- i. CCW**
Rotates turntable counterclockwise. The table will continue rotating until the CCW button is pressed again or the STOP button is pressed.
- ii. STOP**
Stops turntable.
- iii. CW**
Rotates turntable clockwise. The table will continue rotating until the CW button is pressed again or the STOP button is pressed.

7. Troubleshooting

A. *The enclosure door does not close.*

There is an interlock system on the disconnect switch. Turn both the disconnect inside of the enclosure and the red handle/yellow background switch on the front panel to the OFF position. Check that the enclosure lock (operated with a coin or large flathead screwdriver is not interfering. Close the door and press down to fully close the enclosure before you engage the lock and disconnect.

B. *The "Fault" light is illuminated.*

There is an active fault on the VFD. Open the enclosure, take note of the error code displayed on the red display and press the red button on the VFD to attempt to clear the fault. A VFD fault may be inconsequential or indicative of a major problem. Call Carousel USA if the problem persists.

C. *The remote does not work*

Usually, non-functioning remotes are a result of **weak** or **dead batteries** in the remote control. A remote with healthy batteries will have an indicator light that is bright green. A remote with weak batteries will still have a rapidly blinking green light, however the color will be weak in strength/color. A weak remote will not transmit signals properly. Replace batteries accordingly.

D. *Clearing Fault Codes*

To clear Fault Codes press red circle button on the integral keypad of VFD.





CarouselUSA

Standard Turntable Controller Troubleshooting Guide



Revised 01/09/2024

Carousel USA

15206 Ceres Ave, Fontana, CA 92335

www.carousel-usa.com

Proprietary Information

Carousel USA has proprietary rights on the information in this document. It is forbidden to copy, duplicate or disclose the information herein, in whole or in part, or make use of the information, unless permission has been previously obtained, in writing, from Carousel USA.

1. Introduction

This manual provides a step-by-step guide to troubleshooting simple issues related to the Carousel-USA Standard Turntable Controller.

CONTENTS

- 1. INTRODUCTION..... 2**
- 2. INSPECT OPERATIONAL AREA..... 3**
- 3. OPENING THE CONTROL BOX 3**
 - A. TURN OFF MAIN POWER 3
 - B. TURN ON MAIN POWER WITH DOOR OPEN 4
- 4. CHECK CIRCUIT BREAKER 5**
 - A. RESET CIRCUIT BREAKER 5
- 5. CHECK FOR VFD FAULT..... 5**
 - A. CLEAR VFD FAULTS 5
- 6. VFD FAULTS TABLE 6**
- 7. VFD NAVIGATION 9**
- 8. VFD PARAMETERS..... 9**
 - A. FACTORY DEFAULT PARAMETERS..... 9
 - B. PARAMETERS SET BY CAROUSEL-USA 10
 - C. DIAGNOSTIC PARAMETERS..... 10
- 9. CONTROLS TESTING 12**
 - A. TEST ALL CONTROL INPUTS..... 12
 - B. CHECK CONNECTIONS 12
- 10. RE-PAIRING REMOTES TO RECEIVER..... 13**
 - A. PN-R17 14
 - B. T20RX..... 15
 - i. Pairing the Remote..... 15
 - ii. Switching Between Momentary and Latching Button Modes 15
 - C. T60RX..... 16
 - i. Pairing the Remote..... 16
 - ii. Switching Between Momentary and Latching Button Modes 17
 - iii. Interlocking Relay Functionality..... 17

2. Inspect Operational Area

Create a clear and free working area around the turntable, ensuring that there is no debris that could cause interference with the turntable while in motion and that no one would be endangered by sudden movement of the turntable at any time while troubleshooting.

3. Opening the Control Box

A. Turn Off Main Power



Turn the Main Disconnect Switch on the front of the control box to power off the unit. Then, using a large, flathead screwdriver, rotate the key-hole a quarter turn counter-clockwise to unlatch the door, and open the control box.



WARNING

OPENING THE CONTROL BOX EXPOSES LIVE WIRING. ANY WORK PERFORMED INSIDE THE CONTROL BOX IS DONE AT THE USER'S OWN RISK. TO PREVENT ELECTRICAL SHOCK USE CAUTION WHENEVER WORKING NEAR EXPOSED WIRING OR CONNECTIONS.

Page 3 of 17

www.carousel-usa.com

15206 Ceres Ave, Fontana, CA 92335
(626) 334-7190

B. Turn on Main Power with Door Open

With the door still open, return power to the control box by twisting the disconnect shaft a quarter turn clockwise. If the red LED VFD display shown below lights up, skip to Section 5 Check for VFD Fault.



Disconnect Shaft



Red LED VFD Display

4. Check Circuit Breaker

A. Reset Circuit Breaker

If the orange tabs on the circuit breaker have been flipped down, reset them by pushing them back up into the position displayed below. If they are forced down again, the fault condition is still present. Call Carousel-USA at (626)334-7190 and ask for electrical troubleshooting assistance.



Circuit Breaker

5. Check for VFD Fault

A. Clear VFD Faults

On the VFD, if the LED light labeled “FAULT” is lit, press the VFD Fault Reset Button pictured below. If the fault is still present, check the table below to determine what is causing the fault, and next steps to take to correct the fault. If there is no fault present but the table is still not fully operational, skip to Section 9 Controls Testing.



VFD Fault Reset Button

*****DISCLAIMER*****

Before performing any work involving removing wire from terminals, ensure that power is turned off and proper precautions are taken to avoid electrical shock. If ever unsure about how to proceed, please email Carousel-USA at support@carousel-usa.com and provide a brief description of the issue as well as pictures inside the control box or call Carousel-USA at (626)334-7190 and request electrical troubleshooting assistance for a live diagnostic.

6. VFD Faults Table

<u>Displayed Fault Code</u>	<u>Fault</u>	<u>Description</u>	<u>Next Steps</u>
F003	Power Loss	Excessive DC Bus voltage ripple	Check incoming line for phase loss or line imbalance
F004	Under Voltage	DC bus voltage fell below the minimum value	Check incoming line for low voltage or line power interruption. Fault will also appear briefly whenever the control box is powered down via circuit breaker or main disconnect switch
F005	Over Voltage	DC bus voltage exceeded maximum value	Check incoming line for high voltage or transient conditions
F006	Motor Stalled	Drive is unable to accelerate motor	Ensure that VFD parameter P109 is set to 3.0 (See VFD Parameters Section)

F007	Motor Overload	Internal electronic overload trip	Ensure that VFD parameter P103 is set to 4.2 (See VFD Parameters Section)
F008	Heatsink Over Temperature	Heatsink Temperature exceeds a predefined value	Check for blocked or dirty heatsink fins or cooling fan on the VFD. If ambient temperature is below 40°C (104°F) VFD may need replacing
F012	Hardware Over Current	The drive output current has exceeded the hardware current limit	Ensure total load on turntable does not exceed rating for your model
F013	Ground Fault	A current path to earth ground has been detected at one or more of the drive output terminals	Check the motor and external wiring to the drive output terminals for a grounded condition
F038	Phase U to Ground	A phase to ground fault has been detected between the drive and the motor in this phase	Check the wiring between the drive and the motor, check the motor for grounded phase, and replace drive if fault cannot be cleared
F039	Phase V to Ground		
F040	Phase W to Ground		
F041	Phase UV Short	Excessive current has been detected between these two output terminals	Check the motor and drive output terminal wiring for a shorted condition, and replace drive if fault cannot be cleared
F042	Phase UW Short		
F043	Phase VW Short		

<p>F048</p>	<p>Parameters Defaulted</p>	<p>The drive was commanded to write factory default values to all parameters</p>	<p>**IMPORTANT**</p> <p>**See VFD Parameters Section to set parameters before operating turntable. Failure to do so may result in damaged components**</p>
<p>F064</p>	<p>Drive Overload</p>	<p>Drive rating of 150% for 1 minute or 200% for 3 seconds has been exceeded</p>	<p>Ensure total load on turntable does not exceed rating for your model</p>
<p>F070</p>	<p>Power Unit</p>	<p>Failure has been detected in the drive power section</p>	<p>Cycle power and replace drive if fault cannot be cleared</p>
<p>F100</p>	<p>Parameter Checksum</p>	<p>The checksum read from the board does not match the checksum calculated</p>	<p>Set VFD parameter P112 to 1 (See VFD Parameters Section) to reset parameters to factory defaults</p> <p>**IMPORTANT**</p> <p>**See VFD Parameters Section to set parameters before operating turntable. Failure to do so may result in damaged components**</p>

7. VFD Navigation

On power-up, the VFD display will show 0.0 Hz, indicating that the turntable is not moving. Hit enter, and the display will change to show one flashing letter and three solid numbers indicating that the up and down arrows will change the letter. Hitting enter will allow you to change the numbers rather than the letter, and hitting escape will bring you back to 0.0 Hz. Navigate to the parameter you need and hit enter again to view the value currently set to that parameter. This can be changed if needed by using the arrow keys and will be saved once the escape button is pressed, however, you must only change these values if instructed to do so as it may cause damage to the turntable if changed incorrectly.

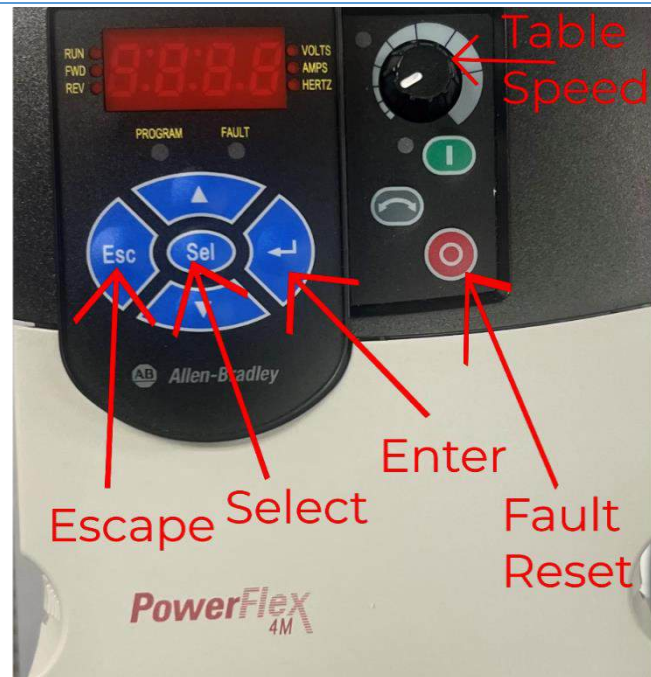

8. VFD Parameters

*****Stop ALL turntable movement before changing parameters*****

A. Factory Default Parameters

If you believe the issue is being caused by parameters in the VFD, begin by factory resetting the parameters. This can be done by setting the value of parameter P041 to 1, however, keep in mind that the parameters listed in the next section will need to be set again to operate the turntable without possible damaging of components.

B. Parameters Set by Carousel-USA

The following are parameters set by Carousel-USA, all others should be set at the factory default. Use these as a guide on which parameters need to be changed if the VFD gets set back to a factory default state (via parameter P041 or P112 being set to 1, or an F048 fault occurring):

P103 (Motor Overload Current): 4.2A

P104 (Minimum Frequency): 15.0 Hz

P106 (Start Source): 2

P109 (Acceleration Time): 3.0 seconds

P110 (Deceleration Time): 2.5 seconds

C. Diagnostic Parameters

The following parameters are used in troubleshooting to determine important control values and cannot be changed.

<u>Parameter Number</u>	<u>Parameter Name</u>	<u>Description</u>
d001	Output Frequency	Frequency present at VFD to motor terminals
d002	Commanded Frequency	Frequency the VFD is attempting to achieve
d003	Output Current	Current present at VFD to motor terminals
d004	Output Voltage	Voltage present at VFD to motor terminals

d006	Drive Status	First number represents deceleration (1 = true 0 = false), second number represents acceleration (1 = true 0 = false), third number represents forward or reverse (1 = forward 0 = reverse), and fourth number represents running or stopped (1 = running 0 = stopped)
d007, d008, and d009	Fault Codes	Displays recent fault codes with d007 being the most recent fault and d009 being third most recent fault
d013	Control Input Status	Displays whether the VFD is being told to stop (second number, 0 = stop command), run in reverse (third number, 1 = run reverse command), or run forward (fourth number, 1 = run forward command)

9. Controls Testing

A. Test All Control Inputs

Begin by attempting to move the turntable in both directions using the selector switch on the control panel door and on each remote you have. Take note which of these moves the table and in what direction. Also note if any of these control inputs do not move the table but make an audible noise from the motor and avoid retesting these until the problem has been identified and rectified.

B. Check Connections

Inspect each control input that did not work, looking for loose connections or damaged wiring. For the door controls, they will be wired directly to the back of the door, and for the remotes, the wiring will be fed into the receiver pictured below.

(Note: The receiver model will be different depending on the use of your turntable, however there should only be one receiver present in the control box).



PN-R17 Remote
Receiver Without
Cover



T60RX Remote Receiver
Without Cover



T20RX Remote Receiver
Without Cover

Also inspect the terminal blocks at the bottom of the control panel that hold wires of the same designation as those going into the faulty control inputs for loose connections and damaged wiring. Should any of the terminal blocks have loose connections, you will need a small flathead screwdriver to reinsert the wire as shown below.

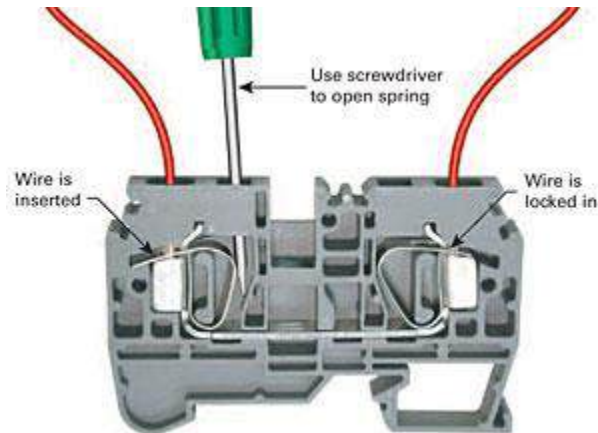

Use a small flathead screwdriver to pry the terminal towards the wire insert to release clamps and pull screwdriver out to re-clamp wire

10. Re-Pairing Remotes to Receiver

Note: More often than not, non-functioning remotes are a result of **weak** or **dead batteries** in the remote control. A remote with healthy batteries will have an indicator light that is bright red and blinks rapidly. A remote with weak batteries will still have a rapidly blinking red light, however the color will be weak in strength/color. A weak remote will not transmit signals properly.

A. PN-R17

- Ensure that the remote has fresh batteries and the yellow on/off switch on the back of the remote is in the upright position
- Remove the cover from the receiver using a Phillips Head Screwdriver.
- Press and release the Function (F) button and LED 5 will light up red.
- Press and release the Select (S) button and all Status LEDs will light up.
- Press and hold Buttons 1 & 2 until all Status LEDs flash twice.
- This will pair all buttons on the remote to the receiver at once.



Buttons and Lights
Inside Receiver Labeled

B. T20RX

i. Pairing the Remote

- Remove the back of the remote using a small flathead screwdriver and ensure that it has fresh batteries
- Remove the cover from the receiver using a Phillips Head Screwdriver
- Simultaneously PRESS and RELEASE the non-functioning button on the remote and the button in the receiver shown below
- The button should now be paired and operating correctly
- Repeat this process with any other non- functioning buttons on the remote



Receiver Pairing Button

ii. Switching Between Momentary and Latching Button Modes

Momentary Mode: requires continual pressing of remote button for turntable operation

Latch mode: requires one press and release to begin operation; pressing same button again stops turntable operation

- PRESS and HOLD both the receiver pairing button in the receiver, and the button on the remote you wish to change modes
- When the red LED in the receiver begins to FAST BLINK, RELEASE both buttons and the operation mode will be changed
- Test operation to ensure it is working as intended
- This process will have to be repeated for each individual remote button to be changed.
- NOTE: This model of receiver allows for each remote button to operate in either mode independent of the others (i.e. one button operates in momentary mode and the other in latching)

C. T60RX

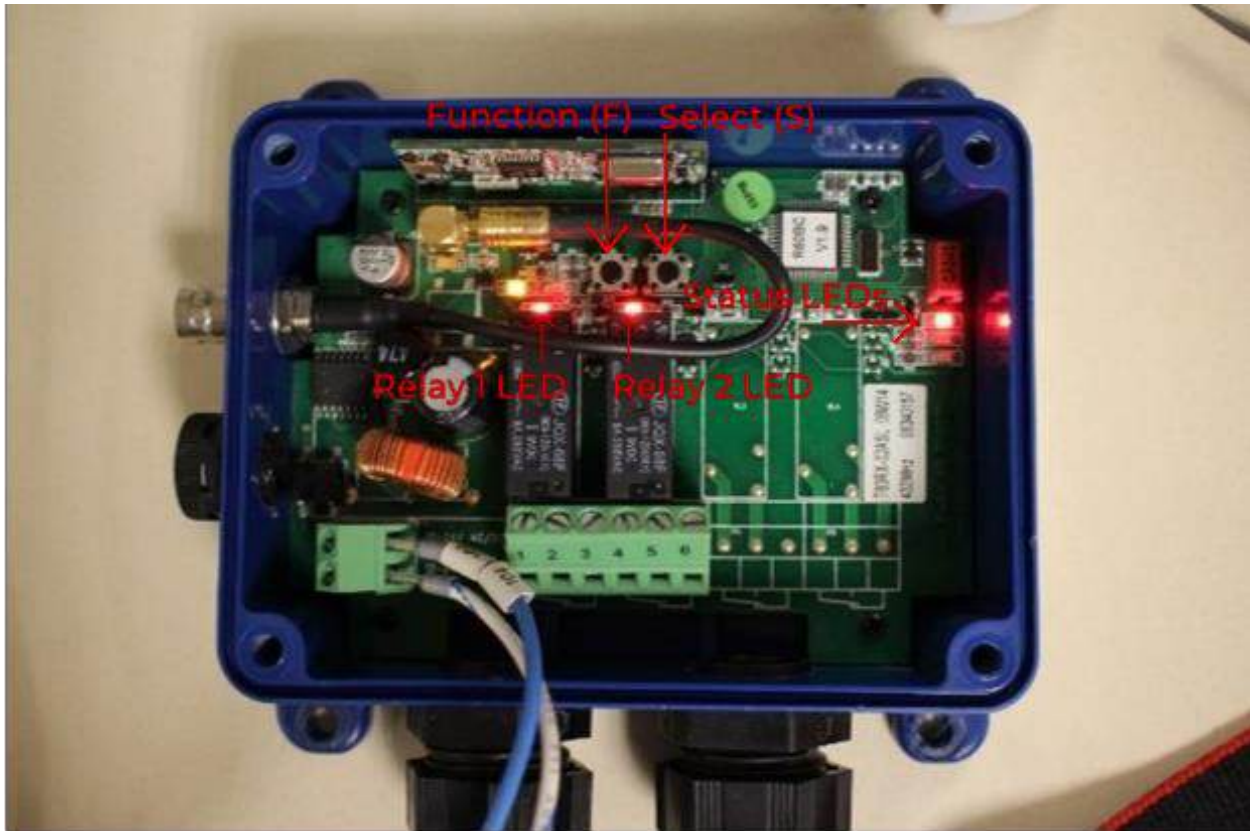

NOTE: Depending on your application, there may be more relays and relay LEDs than are pictured here

i. Pairing the Remote

- Press the Function (F) button in the receiver and the RED Status LED should light up
- Press the Select (S) button in the receiver and all RED Relay LEDs should light up
- Press the Function (F) button to cycle through all available relays until only the relay you wish to pair is lit up (in general, button one pairs to relay one, button two to relay two, and so on)
- Once the relay you would like to pair is lit up, press the Select (S) button twice to enter pairing mode for 6 seconds
- During this time, hold the button on the remote that you wish to pair to that relay until the relay LED goes out
- Repeat this process for each button on the remote that needs pairing

ii. Switching Between Momentary and Latching Button Modes

Momentary Mode: requires continual pressing of remote button for turntable operation

Latch mode: requires one press and release to begin operation; pressing same button again stops turntable operation

- Press the Function (F) button inside the receiver twice and the YELLOW Status LED and first relay RED LED should be lit
- Press the Select (S) button inside the receiver to set latching (YELLOW Status LED ON) or momentary functionality (YELLOW Status LED OFF)
- Press the Function (F) button to switch to the next relay and set momentary or latching
- Once it has cycled through all relays, pressing Function (F) again will exit the mode setting menu
- If any relays have been set with latching mode, the YELLOW Status LED will flash

iii. Interlocking Relay Functionality

Relays 1 and 2 can be interlocked so that triggering either of them will activate them both, as can relays 3 and 4. The process for achieving this is detailed below:

- Press the Function (F) button inside the receiver three times and the GREEN Status LED should be lit
- Press the Select (S) button inside the receiver and relay 1 and 2 LEDs should be lit, pressing Select (S) again will set the interlock between the relays (GREEN Status LED ON = Relays Interlocked; GREEN Status LED OFF = Relays Independent)
- Press the Function (F) button to select relays 3 and 4 (if applicable) and set interlocking mode with the Select (S) button as before
- Press the Function (F) button after all relays have been cycled through to exit the interlocking mode. The GREEN Status LED will flash if at least one relay pair is interlocked

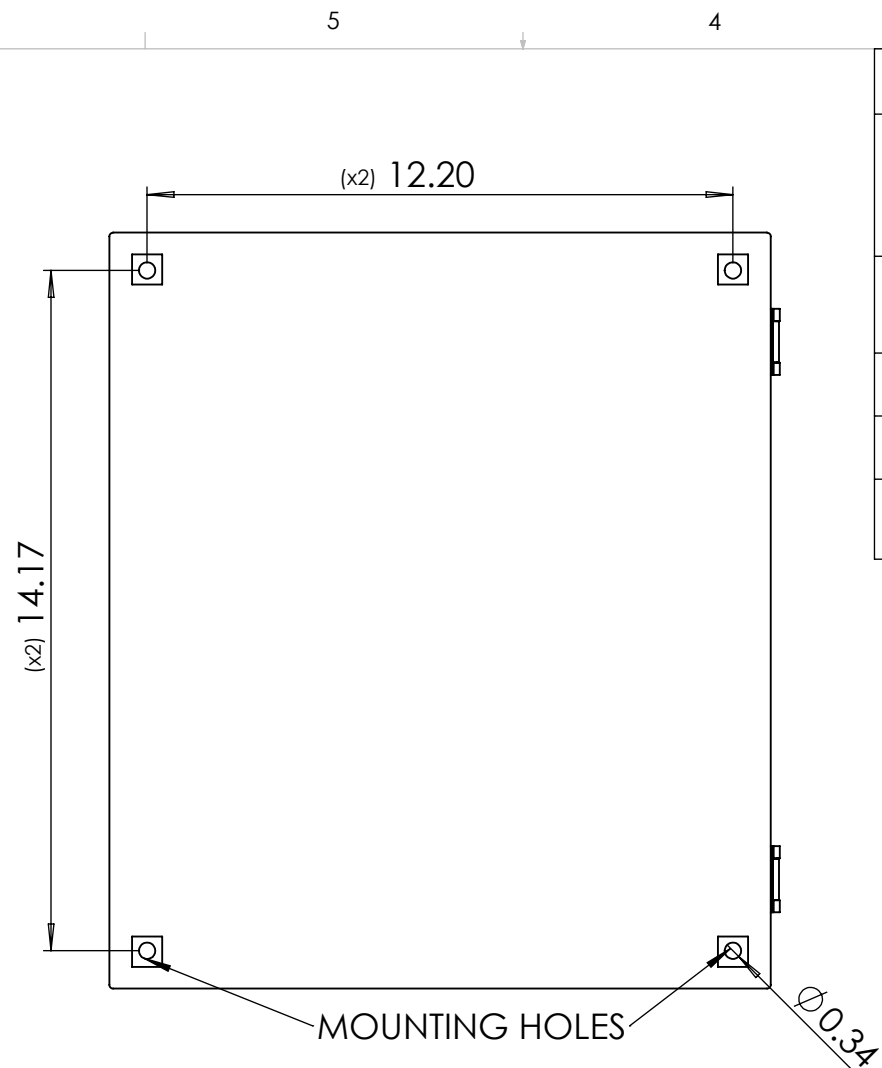
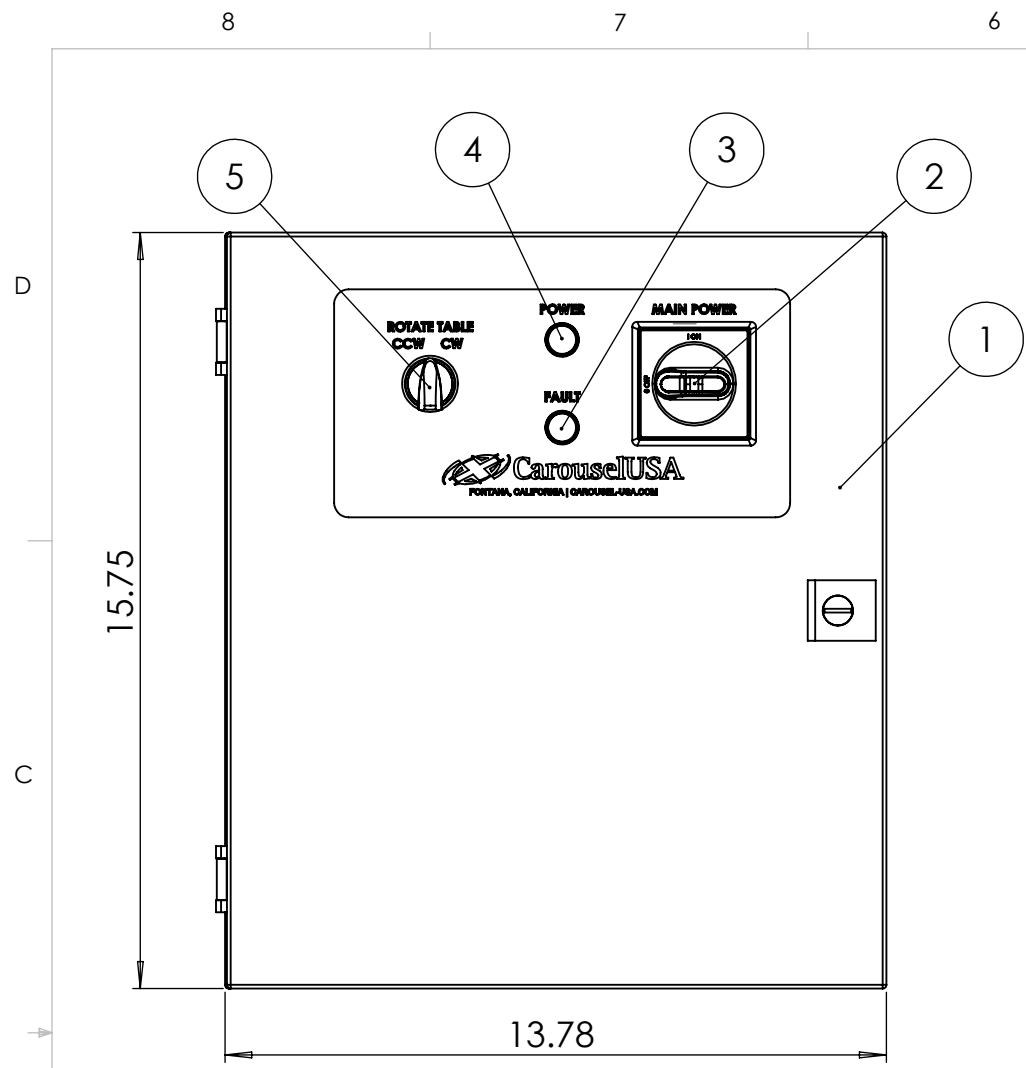

ITEM NO.	PART NUMBER	DESCRIPTION	QTY.
1	JB161406HC	RITTAL CARBON STEEL ENCLOSURE, NEMA 1, 4, 4X. POWDER COAT WHITE.	1
2	OHYS2AJ	ABB MAIN POWER DISCONNECT	1
3	LB1P-1T04R	IDEC FAULT INDICATOR	1
4	LB1P-1T04G	IDEC POWER INDICATOR	1
5	800FD-SB32X20	A.B ROTATIONAL SELECTOR SWITCH	1

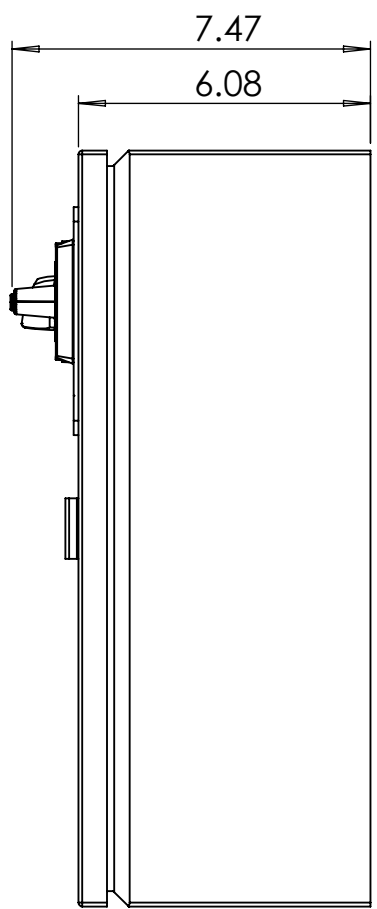
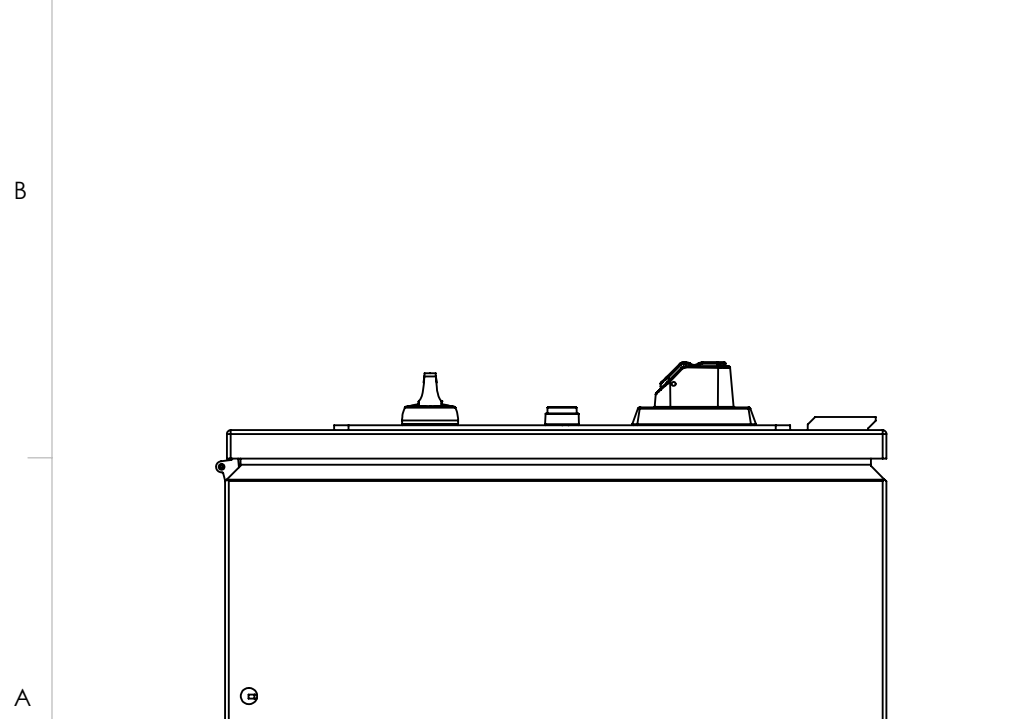
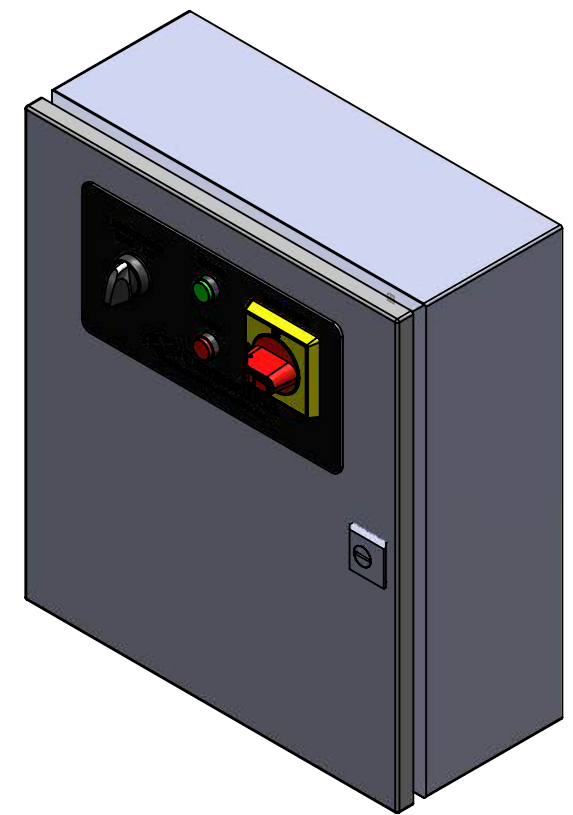

DESIGN BY:	NAME	DATE	
DRAWN BY:	D.Radillo	9/3/24	

UNLESS OTHERWISE NOTED DIMENSIONS ARE IN INCHES

TOLERANCES

X = ± .125
 .XX = ± .0625
 .XXX = ± .010
 FRACTIONAL = ± 1/16"
 ANGLES = ± .5

TITLE: **STANDARD TURNTABLE CONTROLLER SPECIFICATIONS**

Carousel USA 15206 Ceres Avenue Fontana, CA 92335 TEL: (626) 334-7190 FAX: (626) 236-4060 www.Carousel-USA.com	PROPRIETARY AND CONFIDENTIAL THE INFORMATION CONTAINED IN THIS DRAWING IS THE SOLE PROPERTY OF CarouselUSA. ANY REPRODUCTION IN PART OR AS A WHOLE WITHOUT THE WRITTEN PERMISSION OF CarouselUSA IS PROHIBITED.	SIZE B	DWG. NO. C10009	REV B
SCALE: 1 : 4		WEIGHT: 15LBS	SHEET 1 OF 1	

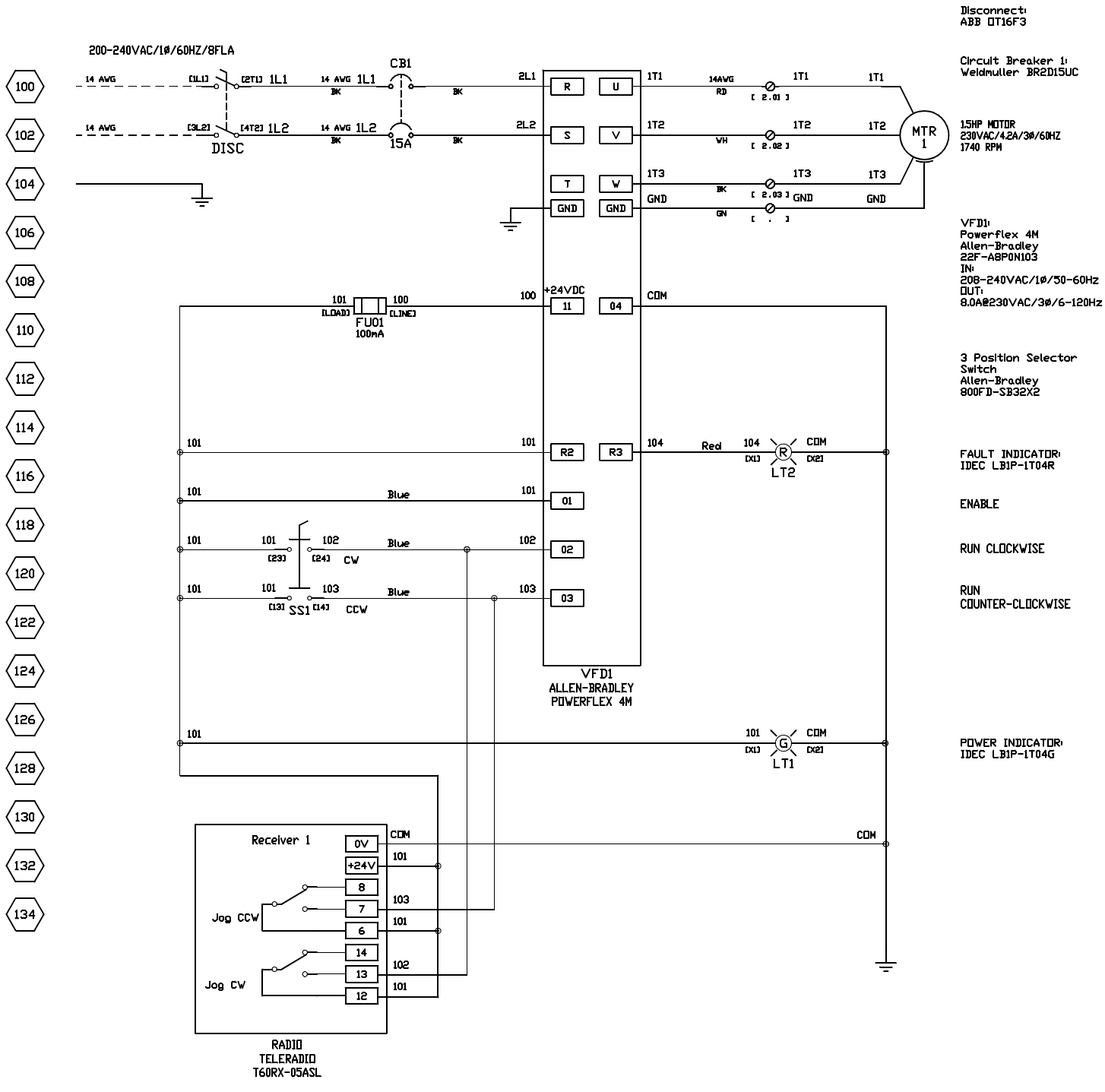

Disconnect:
ABB DT16F3

Circuit Breaker 1:
Weldmuller BR2D15UC

15HP MOTOR
230VAC/4.2A/3Ø/60HZ
1740 RPM

VFD1:
Powerflex 4M
Allen-Bradley
22F-ABP0103
IN:
208-240VAC/1Ø/50-60Hz
OUT:
8.0A@230VAC/3Ø/6-120Hz

3 Position Selector
Switch
Allen-Bradley
800FD-SB32X2

FAULT INDICATOR:
IDEC LB1P-IT04R

ENABLE

RUN CLOCKWISE

RUN
COUNTER-CLOCKWISE

POWER INDICATOR:
IDEC LB1P-IT04G

VFD Parameters:
The following must be set by Installer:
Jumper on "Source"

Powerflex 4M

- P103: 4.2 [A] (Motor ILL Current)
- P104: 15.0 [Hz] (Minimum Frequency)
- P106: 2 [2-Wire] (Start Source)
- P109: 3.0 [Sec] (Acceleration Time)
- P110: 2.5 [Sec] (Deceleration Time)

For field wiring use Copper
or Aluminum Conductors rated
for 60°C (140°F)
Terminal torque 7lb.in.

CUSTOMER APPROVAL		TOLERANCE BLOCK		Carousell USA			
APPROVED	DATE	DECIMALS: XX ± 0.050 XXX ± 0.020 XXXX ± 0.010	ANGULAR: ± 1° DIMENSIONS ARE IN INCHES	DESIGNED BY: _____ ENG. APPROVAL: _____ MFG. APPROVAL: _____ TITLE OR DESCRIPTION: STANDARD CONTROLS 1.5 HP SIZE: A AUTOCAD FILE: _____ DRAWING NUMBER: C10009 REV: B			
THIS DOCUMENT CONTAINS CONFIDENTIAL OR PROPRIETARY INFORMATION OF CAROUSEL USA. NEITHER THE DOCUMENT NOR THE INFORMATION CONTAINED THEREIN IS TO BE REPRODUCED, DISTRIBUTED, USED OR DISCLOSED EITHER IN PART OR IN WHOLE EXCEPT AS SPECIFICALLY AUTHORIZED BY CAROUSEL USA IN WRITING, AND MUST BE RETURNED PROMPTLY WITH COMPLETED MATERIAL, QUOTATION, OR UPON REQUEST OF CAROUSEL USA.		MATERIALS USED:					
		REVISION DATE: 6/29/2021					